

2019  
2020

# ***Burbank Unified School District HIGH SCHOOL Course Description Guide***



BURBANK HIGH SCHOOL – JOHN BURROUGHS HIGH  
SCHOOL  
INSTRUCTIONAL SERVICES

BURBANK UNIFIED SCHOOL DISTRICT | 1900 W. Olive Ave. Burbank, CA 91506

## CONTENTS

GENERAL INFORMATION .....	1
STUDENT INFORMATION .....	4
WHEN READING THIS GUIDE .....	7
ALTERNATE CREDITS .....	9
VALEDICTORIAN AND SALUTATORIAN SELECTION CRITERIA .....	9
GRADUATION HONOR CORDS .....	10
WHEN MAKING COURSE SELECTIONS .....	10
POST-SECONDARY EDUCATIONAL OPTIONS.....	11
COURSE DESCRIPTION GUIDE BY DEPARTMENT .....	15
ENGLISH DEPARTMENT.....	16
ENGLISH LANGUAGE DEVELOPMENT (ELD) DEPARTMENT .....	19
FINE ARTS DEPARTMENT .....	21
WORLD LANGUAGES DEPARTMENT .....	33
MATHEMATICS DEPARTMENT .....	37
PHYSICAL EDUCATION DEPARTMENT.....	43
ATHLETICS.....	46
PRACTICAL ARTS DEPARTMENT AND CAREER TECHNICAL EDUCATION.....	49
SCIENCE DEPARTMENT .....	65
SOCIAL SCIENCE DEPARTMENT.....	69
SPECIAL EDUCATION DEPARTMENT .....	73
NON-DEPARTMENTAL COURSES.....	74

# HIGH SCHOOL PARENT/STUDENT GUIDE

## GENERAL INFORMATION

**Access:** The Burbank Unified School District is committed to equal opportunity for all individuals in education. **District programs and activities shall be free from unlawful discrimination, including discrimination against an individual or group based on race, color, ancestry, nationality, national origin, immigration status, ethnic group identification, ethnicity, age, religion, marital status, pregnancy, parental status, physical or mental disability, sex, sexual orientation, gender, gender identity, gender expression, or genetic information; a perception of one or more of such characteristics; or association with a person or group with one or more of these actual or perceived characteristics. The Burbank Unified School District is committed to equal opportunity for all individuals in education.** This nondiscrimination policy covers admission and access to the District's programs and activities. The lack of English language skills will not be a barrier to admission and participation in the District's programs. When signing up for classes, every attempt will be made to give students their first or second choices; all decisions are made on a space-available basis. Furthermore, although many courses are listed in this guide, not all classes are offered each semester or year. Inquiries regarding the equal opportunity policies, and the filing of grievance procedures covering discrimination complaints, may be directed to each school's administration. In addition, information on the Uniform Complaint Process can be found at the District website.

---

## CREDIT FOR OFF-CAMPUS SCHOOLING

There may be instances when students wish to enroll in an off-campus program, such as one given at a local community college. If this situation occurs, the student must fill out the appropriate application and receive written permission from the Director of Secondary Education in advance in order to receive high school credit. The high school counselors can facilitate this process.

---

## GRADING SYSTEM

Report cards are distributed to students after approximate five-week instructional units. Only final semester grades are mailed home. It should be kept in mind that the only grades which are considered permanent, and therefore recorded on transcripts, are those issued at the end of each semester. Progress report grades do not become a part of the permanent record, but keep students and parents apprised of how the student is progressing in each of the enrolled subjects.

---

## HONORS AND ADVANCED PLACEMENT CRITERIA

The Burbank Unified School District aims to provide access to all advanced courses of study to students who indicate a desire for more challenging coursework and who have demonstrated the ability to be successful as indicated by prior performance. If a student receives an “A” or a “B” in the prior course, he or she may self-select an Honors or Advanced Placement level course. If a student receives a “C” in a prior course, he or she must meet with the counselor to discuss class expectations and schedule load before the class will be approved. If a student receives less than a “C”, he or she is not eligible for an Honors or Advanced Placement course.

---

## PARENT PORTAL

The Parent/Student Portal available through [www.burbankusd.org](http://www.burbankusd.org) provides information regarding student’s attendance and grades. Parents can get login information at the student center or counseling office of their child’s school.

---

## CAREER TECHNICAL EDUCATION (CTE) PROGRAM

Classes are open to grades 9-12 with completion of prerequisite courses, except for Retail Marketing, which is limited to students age 16 and up.

CTE classes are for students who are interested in exploring careers, working immediately following high school, or learning marketable skills to work their way through college. This program offers many vocational courses which give students the opportunity to develop entry-level job skills. In addition, the District has three NAF academy programs. These are Business, Medical and Engineering. These are CTE pathway programs that provide both academic and vocational instruction.

---

## STUDENT SERVICES:

### CAREER CENTER –

---

The Career Centers of both Burbank and Burroughs High Schools maintain an extensive library of current college catalogs and directories for student use. Information on private schools, military academies, career technical education/vocational schools, study abroad, and summer programs is also available. The Career Centers also maintain an extensive library of occupational and vocational materials. Students can explore career options, career testing, and a wide variety of printed material. College representatives, military recruiters, and representatives from various occupational areas are scheduled throughout the year to speak with interested students.

### COUNSELING SERVICES –

---

Students and parents are urged to take advantage of the academic and personal counseling opportunities that are made available to them. They may arrange to see their counselor during the

day; if the counselor is not available, students may sign up for an appointment. Additional counseling services are available to students, with parent permission, through the Family Services Agency of Burbank. Drop-in services are also available through the Care Centers at each high school. Requests for student records, other than transcripts, are made through the Counseling Office. To order a transcript, visit [www.parchment.com](http://www.parchment.com)

#### Library/Media Center –

The libraries have developed into Campus Research Centers. Students have access to both print and on-line resources to help meet their research needs. Each library houses student computers with internet access and offers a wide selection of both fiction and non-fiction print titles which are available for check-out by the students. The libraries strive to support the various classroom curriculums.

#### TRANSCRIPTS –

---

Students may order transcripts through the school website for each high school. Students who have graduated after 2003 may complete the process electronically. Students who graduated prior to 2003 will have to complete an application also located on the school website.

## STUDENT INFORMATION

---

### ATHLETICS:

There are a large variety of athletic teams (varsity, junior varsity, freshmen) available to high school students who maintain at least a 2.0 GPA and who are passing at least four classes.

---

### ATTENDANCE:

Compulsory attendance laws require that parents send their children to school. The law further states that a student must attend every scheduled session of every class, even if failure is imminent. The law applies to all students until they reach 18 years of age. Absences and tardies must be excused within three (3) days of the absence/tardy. A parent/guardian needs to call the Attendance Office at their high school each day that their student is absent or tardy. If you receive an automated call the evening your student is absent, this indicates that the school did not receive a call from a parent/guardian to excuse. All senior students' attendance records must be cleared or they will not be able to participate in Senior activities and graduation.

---

### CELL PHONES/BRING YOUR OWN DEVICE POLICY:

1. Students may possess or use personal electronic signaling devices on school campus provided that such devices do not disrupt the educational program or school activities and are not used for illegal or unethical activities such as cheating on assignments or tests or accessing inappropriate content.
2. The District assumes no responsibility for loss, theft, damage, or maintenance of student owned devices that are brought to school. Students are solely responsible for the security of their own devices.
3. Electronic signaling devices shall be turned off and kept out of sight during class time or at any other time as directed by a school district employee, except where deemed medically necessary or when otherwise permitted by the teacher or administration. No student shall be prevented from using his/her cell phone in case of an emergency, except where that use inhibits the ability of school district employees to effectively communicate instructions for the safety of students.
4. The District assumes no responsibility for data used by students on individual cell plans.
5. Use of electronic devices to record video, pictures, and/or audio (while on campus) is not permitted unless given specific permission by staff member.
6. Students are responsible for bringing fully charged devices to school. Devices cannot be plugged in and left in classrooms or other areas of the school. Teachers and staff are not responsible for devices left in classrooms or other areas of school. Teachers and staff have discretion to allow charging if they deem it to be appropriate.

7. Devices are subject to search by school administration and/or law enforcement when it has been suspected that they have been used in an unlawful manner or there is reasonable suspicion of wrongdoing; such as (but not limited to) cheating on tests, unauthorized recording (audio and/or visual). Otherwise, school district employees will not search a device without the express authorized consent of the student and the student's parent or legal guardian.

8. Students are not permitted to record images, media, or student work without prior consent and authorization from a school administrator or teacher.

9. High school students may use electronic devices during passing periods, nutrition, lunch, and after school provided that they are not oppositional to any of the above policies. Middle school students are only permitted to use devices during class with staff members' permission.

10. Students may not use electronic devices in ways that would disrupt educational or other school activities.

11. Students cannot be required to use their own personal devices. The District expects that teachers will provide other tools for students to use (as required by instruction and equity of access) when personal devices are not available or students choose not to use them.

12. Students may not share their personal electronic devices (for classroom use).

13. Violations of these conditions may result in progressive discipline. If a student's use of an electronic signaling device causes a disruption, a school district employee, on the first offense, may direct the student to turn off the device or reprimand the student. On subsequent offenses, the employee may confiscate the device and return it to the student at the end of the class period, school day or activity. A student's right to carry such devices may be revoked for subsequent offenses except where deemed medically necessary. Students may be subject to other disciplinary measures when their use of an electronic signaling device violates independent school rules, such as prohibitions on cheating.

---

#### CLUBS:

The high schools have a great number of clubs which meet on campus, all of which are a great way to get involved, support your school and have fun. A current list of all the clubs on campus, as well as applications to start a new club, can be picked up in the ASB Room.

---

#### COUNSELORS:

Counselors are available to work with academic, instructional, college and career as well as social or personal issues. Students may make appointments to see their counselor on a request basis. Students who fall behind in credits because they have failed classes are called in by their counselor to discuss credit recovery. Counselors hold meetings with students to discuss graduation requirements and course registration.

---

#### DAILY BULLETIN:

The bulletin is updated each day and posted on the school's website to relay information to the students. Pertinent information regarding classes, campus news, holidays, activities, clubs, and athletic schedules are updated daily as a primary means of communication for students. Time is allotted at the beginning of period two for the bulletin to be read or televised. Students are responsible for listening to the bulletin each day or watch the telecast announcements.

---

#### DANCE REGULATIONS:

Several dances are scheduled throughout the year. A valid I.D. card must be presented for admission to dances. Guest passes will be available from the front office. Guests are required to have a valid picture identification. Middle School students and adults 21 and over may not attend high school dances. All school rules apply at dances. Once a student leaves the dance, s/he will not be allowed to reenter, and will be expected to leave the campus.

---

#### FEES:

Pupils are prohibited from being required to pay a fee for participation in an educational activity offered by a school or District that constitutes an integral fundamental part of elementary and secondary education, including, but not limited to, extracurricular and co-curricular activities.

---

#### LOST & FOUND:

Check lost and found at each school for all lost items. Textbooks are returned to the library. Lost and found will be cleaned out quarterly for donation to charity.

---

#### LUNCH PASSES:

If a junior or senior student has been issued a lunch pass through the Discipline Office, he/she may leave campus ONLY during lunch. Passes are valid only during the scheduled lunch period; therefore, if a student leaves campus on a lunch pass and does not return for afternoon classes, a parent must call the same day to excuse those classes. If a call is not received the same day, the absence is considered a truancy and cannot be excused. Passes may be revoked for disciplinary, attendance or academic reasons.

---

#### P.E. UNIFORMS:

Uniforms approved by each school are required at all times. Uniforms may be purchased at the student store. Alternatively, students may also wear a shirt and a pair of shorts in the same colors, but may not wear their school clothes. Check with your school for guidelines. A designated lock may be required for P.E. lockers which can be purchased in the student store.

---

#### SKATEBOARDS, ROLLER BLADES & BICYCLES:



Students are not permitted to ride skateboards, roller blades or bicycles on the campus. Bicycles and skateboards must be secured in the racks provided.

---

#### STUDENT STORE:

The student store is open during nutrition, lunch and designated hours. School supplies, locks, P.E. clothing and spirit wear are regularly kept in supply.

## WHEN READING THIS GUIDE

When reading the *High School Parent/Student Guide*, students and parents will need to keep in mind that this document represents the instructional programs housed at both Burbank and John Burroughs High Schools. All courses are not offered at both schools; however, the high schools in the District offer equally comprehensive and challenging programs. The terms and definitions below will make reading this guide easier and more accessible.

---

#### ADDING/DROPPING CLASSES:

Students may change courses for credit up to the end of the 3<sup>rd</sup> week of a semester. No changes may be made after the 3<sup>rd</sup> week.

---

#### COURSE DESCRIPTION:

This *High School Parent/Student Guide* contains details of the main activities and content of each course, and in some instances, an indication of expectations of performance for those students who enroll in the course.

---

#### COURSE OFFERINGS:

Every class listed in this *Guide* may not be offered due to enrollment or staffing considerations; however, all effort will be made to provide students with the maximum number of course offerings possible.

---

#### LENGTH OF CLASS:

Classes are either one semester or one year in duration. When a student enrolls in a year-long class, he/she will remain in the class for its duration.

---

#### NOTATIONS:

Classes designated with the letters “AB”: “A” indicates the first year, and “B” the second year of a two-year class. When a course is followed by a number, it either refers to the grade level (9=freshman, 10=sophomore, etc.) or the year (1=1<sup>st</sup> year, 2=2<sup>nd</sup> year, etc.)

---

PREREQUISITES:

This section in the course description section shows the prerequisite(s) or conditions necessary for admission to the class. If the line indicates “None” no specific prerequisites exist.

## ALTERNATE CREDITS

Some courses are listed in one department but may be applied to another department for satisfying its graduation requirement. The complete list of courses which have credit options are listed below:

COURSE	DEPARTMENT LISTED IN	MAY BE APPLIED TO
Accounting	Practical Arts	Mathematics
Advanced Photo	Fine Arts	Practical Arts
Chamber Choir	Fine Arts	PE
Color/Winter Guard	Fine Arts*	PE
Dance	Physical Education	Fine Arts
Advanced Dance	Fine Arts	PE
Dance Production	Fine Arts	PE
Digital Art and Video Production	Fine Arts	Practical Arts
Digital Media	Practical Arts	Fine Arts
Marching Band	Fine Arts	PE
Digital Photo/Photography	Practical Arts	Fine Arts
Stagecraft Tech	Practical Art	Fine Arts
Video Production	Fine Arts	Practical Arts
Yearbook	Fine Art	Practical Arts

\*Not a UC approved course under "f" – visual and performing arts

## VALEDICTORIAN AND SALUTATORIAN SELECTION CRITERIA

The valedictorians and salutatorians will be selected using the following criteria:

The principal of each high school will begin with the top 20 ranked students using weighted Grade Point Averages (GPA's). The student with the highest weighted average will be the valedictorian. In case of a tie, the students will be co-valedictorians. The student with the next highest GPA will be the salutatorian. In case of a tie, the students will be co-salutatorians.

The high school principals will publicly announce the valedictorian and salutatorian at a mutually agreed upon time soon after the 10-week spring grading period.

A student must be enrolled in either BHS or JBHS for his/her entire senior year in order to be considered for the honor of valedictorian or salutatorian. Since the deadline to add/drop a class is the third week of the semester,

students must be enrolled in either BHS or JBHS by the end of the third week of the first semester of his/her senior year in order to be considered for either of these honors.

This selection method became effective with the class of 2015.

## GRADUATION HONOR CORDS

Graduating high school seniors may wear honor cords at the graduation ceremony. The honor cords that students wear must be from a national or state academic organization or honor society, or be approved by the principal.

## WHEN MAKING COURSE SELECTIONS

Selection of high school courses should be given thoughtful consideration. The courses students choose will have a definite impact on their high school achievement and post-secondary options. When reading this *Guide*, students should consult with their parents and counselor to select a schedule that challenges them, but does not overburden the students' schedules. A schedule should reflect post high school plans and should help prepare each student to live successfully, but also leave room for exploration and interest.

Alternative classes should be listed on the selection sheet in case of scheduling conflicts. If no alternate is selected, a course may be assigned by the counselor.

Program changes are not encouraged and may not always be accommodated. Students must initiate all requests for change with their counselor and follow the approved petition process during the first three weeks of the semester.

Because it is important for students to learn to work with a variety of personalities, they may not select their own teachers. The counselors are available to help work toward resolution if classroom conflicts should arise between student and teacher.

Students in grade 12 must be enrolled in a minimum of six courses in the first semester and five courses in the second semester (unless exempt under Education Code Section 46145).

## POST-SECONDARY EDUCATIONAL OPTIONS

Success in high school is still the best predictor for success in college. Students may ensure their success by obtaining a solid educational background. It is recommended that students inquire about Honors and Advanced Placement sections in the courses they plan to take and that they include as many courses in English, mathematics, science, social studies, and foreign language as possible, but carry manageable and reasonable course loads. Students should be aware of and take the courses listed on page 9 in considering attendance at a four-year college. Taking the PSAT, SAT, and ACT and attending college information meetings during the junior year is strongly encouraged.

When thinking about college, students should consider all their options. There are many independent colleges and career technical schools, as well as the extensive offerings in California's higher education system. The State of California maintains three different college systems. Each of these has its own entrance requirements. For private or out-of-state colleges, students should consult the catalog section in the Career Center at their school. In the spring of the junior year, students should consult counselors regarding admissions procedures.

---

### DUAL ENROLLMENT

Both comprehensive high schools offer some college courses on campus that may count for both high school and college credit. Students must have a 2.0 GPA in the semester prior to application in order to qualify to take the classes. The course offerings are posted each semester.

---

### CAREER TECHNICAL SCHOOLS

Students whose interests and talents center around school workshops, labs, and work experience may profit most by short-term, highly specialized training. Such training is available through the Los Angeles County Regional Occupational Program (ROP), community colleges, and trade or technical schools. Students should talk with their counselors and teachers in their area of interest to investigate programs available to them.

---

### CALIFORNIA COMMUNITY COLLEGES

There are 114 community colleges in California, where students can complete the freshman and sophomore years of a university education. Community colleges also offer certificate programs varying in length from one semester to two years, which prepare students for occupations and positions that do not require a university degree.

#### *ELIGIBILITY*

- Open to all high school graduates or those who pass the California High School Proficiency Examination.
- Open to any adult of at least age 18 years of age.

#### *PROGRAMS*

There are three main programs, which are offered by California Community Colleges:

1. **The Transfer Program** is intended for students who want to complete the first two years of college

before transferring to a four-year college. While in high school, these students should select and meet entrance requirements for a four-year college before entering the community college. More California State University students complete their first two years at a community college than complete those years at the university.

2. **The Certificate Program** is planned for those who wish specific training in a career field. Since not all courses are offered at any single college, students should contact the community college of their choice to see if their desired career program is offered. A student completing the career course requirements will be granted a Certificate of Achievement.

3. **The Associate of Arts Degree Program** is intended for those who want to end their higher education after the first two years of college. When students start classes at community colleges, they should familiarize themselves with requirements so the classes they take will lead to the AA Degree. These courses will require a college prep background in high school.

Both Glendale Community College and Los Angeles Valley College offer numerous certificate and two-year degree programs.

---

#### CALIFORNIA STATE UNIVERSITY (CSU) SYSTEM

There are twenty-three campuses in this system, ranging from Humboldt near the Oregon border to San Diego on the Mexican border, with an enrollment exceeding 484,300 students and more than 1,600 degree programs. The campuses are as follows: Bakersfield, Channel Islands, Chico, Dominguez Hills, East Bay, Fresno, Fullerton, Humboldt, Long Beach, Los Angeles, Maritime Academy, Monterey Bay, Northridge, Pomona Polytech, Sacramento, San Bernardino, San Diego, San Francisco, San Jose, San Luis Obispo Polytech, San Marcos, Sonoma, and Stanislaus. The State University System has entrance requirements designed to admit 33% of the graduates of California high schools. Eligibility for entrance depends upon the GPA combined with a score on either the SAT or the ACT admission tests. The rule of thumb is that the higher the GPA, the lower the test score required, and conversely, the lower the GPA, the higher the test score required. October 1<sup>st</sup>– November 30<sup>th</sup> of the senior year is the initial application-filing period for the following fall. More information can be found at the CSU website: [www2.calstate.edu](http://www2.calstate.edu).

The University of California and California State University have agreed to adopt the same pattern of academic courses required for freshman eligibility. The minimum requirements for both systems are the following: four years of English, three years of mathematics, two years of history/social science, two years of laboratory science, two years of language other than English, one year of visual or performing arts and one year of electives. A grade of “C” or higher is required in each course.

**Examination Requirement:** All students must submit scores from either SAT, SAT Subject tests or ACT.

**Grade Requirement:** Overall GPA for grades 10-12 excluding PE is combined with SAT I or ACT scores to determine admission qualifications. All courses taken to meet the requirements must be completed with a grade of “C” or higher. Details on calculating GPA, including the use of Honors or Advanced Placement course grades, are available from counselors. Incoming freshmen must have an eligibility index which places them among the upper one-third of California high school graduates.

## University of California (UC)

There are ten campuses in this system, located at Berkeley, Davis, Merced, San Francisco, Santa Cruz, Santa Barbara, Los Angeles, Irvine, Riverside, and San Diego. There are currently 251,700 students in attendance. To be eligible for admission, students must satisfy all requirements listed below. The UC System admits approximately the top one eighth, or 12.5%, of all high school graduates. November 1-30 of the senior year is the initial application filing period for the following fall.

**Grade Requirement:** All courses taken to meet the entrance requirements must be completed with a minimum grade of “C” or higher. Details on calculating grade point averages, including the use of Honors or Advanced Placement course grades, are available from counselors. A combination of GPA and SAT or ACT test scores is the primary basis for admission to the University of California system; however, the personal statement and extracurricular activities are also important components of the application.

**Minimum Course Requirements:** All courses intended to meet UC requirements must be designated college preparatory.

Two years History/Social Science

Four years English

Three years’ college prep Math required, with four years recommended

Two years Lab Science\* required, three or more years recommended

Two years Foreign Language, three or four years recommended

One year of Visual or Performing Arts

One year of university-approved electives selected from at least two areas:

4<sup>th</sup> year Advanced Math; 3<sup>rd</sup>, 4<sup>th</sup>, or 5<sup>th</sup> year Foreign Language, additional year(s) of Lab Science, Social Science, Visual/Performing Arts (limited)

\* One year of lab science may be completed in ninth grade. Biology and Chemistry or Physics required.

**Selectivity:** Because several UC campuses have more applicants than they can accommodate, they emphasize the breadth (range of course work taken) and depth (number of years taken, Honors and AP courses) when making admission decisions.

More specific entrance criteria for each school and how to calculate the GPA can be found at the UC website, [universityofcalifornia.edu](http://universityofcalifornia.edu)

---

### EXAMINATION REQUIREMENT:

- 1) All students must submit scores from either SAT or ACT.
- 2) All students are strongly recommended to submit scores from SAT subject tests and are urged to check with the college or university to whom he/she is applying.

Testing must be completed by December of the senior year for all applications.

**BUSD College Preparatory Subjects** (these satisfy the UC “a-g” and CSU subject requirements):

a. *History--2 years*

Government, Transitional Government, AP Government, Honors Government, Mock Trial  
AP European History, United States History, SDAIE U.S. History, AP U.S. History, World History, SDAIE  
World History, AP World History

b. *English--4 years*

English 9-12, Transitional English 9-12, Honors English 9-10  
AP English Language, AP English Literature  
Advanced ELD 3,4 (maximum 1 unit with other ESL-type English courses)  
Expository Reading and Writing Course (ERWC)

c. *Mathematics--3 years required, 4 recommended (\*may only be used for the “c” requirement)*

\*Algebra, \*Geometry, \*Algebra 2, \*Trigonometry/Statistics, Intro to College Math, Pre-Calculus,  
\*SDAIE Algebra, \*SDAIE Geometry, \*SDAIE Algebra  
2, AP Calculus AB, AP Calculus BC, AP Statistics

d. *Laboratory Science--2 years required, 3 recommended*

Anatomy and Physiology  
Earth and Space Science, Earth and Space Science SDAIE, Biology, SDAIE Biology, AP Biology,  
Honors Biology, Chemistry, Honors Chemistry, SDAIE Chemistry, AP Chemistry, Physics, AP  
Physics, AP Physics 2, AP Physics C, Micro/Marine Biology, Advanced Astronomy

e. *World Language--2 years required, 3 recommended*

French 1-3, AP French 4  
Spanish 1-3, AP Spanish Language 4, AP Spanish Literature 5  
Spanish for Spanish Speakers 1-2  
American Sign Language 1-3

f. *Visual/Performing Arts—1 year required*

Advanced Art, Advanced Art/Portfolio, Advanced Photography, AP Studio Art, Art History, Concert  
Band, Jazz Ensemble, Marching Band, Orchestra, Wind Ensemble, Chamber Choir, Madrigal Choir,  
Mixed Choir, Musical Theater, Photography 1, Photography 2, Animation, Art Structure 1, Art  
Structure 2, Sculpture 1, Sculpture 2, Dance 1, Digital Art and Video Production, Drama 1, Dance  
Production. Play Production (For updated list of UC approved courses, see your counselor or  
[www.ucop.edu/doorways](http://www.ucop.edu/doorways))

g. *Elective Courses* (all courses listed under a-e with the exception of \*math courses plus  
the following): History -- all courses listed under “a”

English -- Journalism,  
Advanced Mathematics -- AP Computer Science A, Honors Computer Science AB, Pre-Calculus,  
Calculus, Statistics, Computer Science  
Laboratory Science--all courses listed under “d”  
Foreign Language--all courses listed under “e” (with the exception of first year language)

Social Science--Economics, SDAIE Economics, Honors Economics, AP Economics, Psychology, Sociology  
Sports Medicine

Note: Only underlined courses will be assigned extra honors credit: A=5,



B=4, C=3 For complete listing of UC approved courses, see [www.ucop.edu/doorways](http://www.ucop.edu/doorways)

---

## INDEPENDENT/PRIVATE COLLEGES

There are hundreds of independent colleges and universities around the country with a wide range of characteristics that make them attractive to students. Since the tuition is paid by the student rather than by public tax dollars, the cost to the family may be greater than the cost in a public university. Financial aid is often available, based upon need.

While some independent colleges are in the most competitive category for admission, others are looking for students in the top half of their graduating classes. In addition to the typical admission requirements of subjects, grades, and test scores, the independent colleges often take a closer look at individual students by requiring letters of recommendation and, sometimes, personal interviews. Most college prep students will meet the admission criteria of one or more campuses.

There are great differences in size, educational purpose, and emphasis among these institutions. Some are small and offer students a personalized campus. Some campuses may have a particular vocation or religious emphasis. There are 70 private colleges with over 125 possible majors available in California. Specific information about the requirements and educational opportunities available at any independent college in the United States may be obtained through the high school Career Center or directly from the institution.

---

## NATIONAL COLLEGIATE ATHLETIC ASSOCIATION (NCAA)

Students who are planning to participate in athletics at the college level are required to complete a specified set of core courses. The courses must be on the NCAA approved list. The courses on the list are noted in the course description.

### **Core Courses**

This formula from the NCAA website will help you meet Divisions I and II core-course requirements.

4 x 4 = 16

+ 4 English courses (one per year)

+ 4 math courses (one per year)

+ 4 science courses (one per year)

+ 4 social science courses (one per year)

= **16 NCAA CORE COURSES**

For more information about the requirements to compete in athletics at the college level, please visit the NCAA website, [www.ncaa.org](http://www.ncaa.org)

## ENGLISH DEPARTMENT

All students must be enrolled in an English class every semester and must earn a total of 40 units of English credit in order to graduate. Ninth through twelfth grade courses are yearlong. Courses comply with the Common Core State Standards for English Language Arts. Students will master a variety of language arts skills with both fiction and nonfiction pieces. College Preparatory English classes require that students create their own meaning, integrate skills into processes and use what they have learned to approach real-world problems, with persistence. These activities develop a learning community that is robust, engaging and appropriately challenging. Rigorous lessons require students to go beyond a surface understanding of the material. These lessons, by design, foster students' ability to think and learn for themselves.

**Our program fosters persistence.** When students must dig for answers, they discover the value of a search, A little effort leads to greater ones.

**Our program fosters resilience.** When students learn to engage in rigorous thinking and inquiry, they learn how to manage and work through frustration to solve problems on their own. They develop tolerance for uncertainty, acquire the skills and the disposition to handle struggle, and build a track record overcoming tough challenges.

**Our program fosters flexibility.** Rigorous instruction helps students grasp that learning is messy and unpredictable, and that understanding is something to be pursued through multiple pathways that are often complex, layered and ambitious.

### ADVANCED PLACEMENT/HONORS ENGLISH

---

The English Honors program is a program designed to prepare students for the Advanced Placement Examination in the Language and Composition Literature administered annually by the College Board. The English Honors course sequence is intended for the highly motivated student who has good citizenship and study habits, and who desires to work at an accelerated rate. We expect AP/English Honors students to be highly proficient in the English language; they should read critically, be sophisticated enough to read and discuss literature containing mature themes, write with precision, have an understanding of grammatical sentence structure, and actively participate in class discussions, as well as oral presentations.

---

#### CREDIT REQUIREMENTS:

Students must earn at least 40 credits for graduation.

---

#### RECOMMENDED COLLEGE PREP COURSES

Fulfills "b" requirement for UC and CSU

English 9, 10, 11, 12

Honors English 9, 10, AP Language and Composition, AP English Literature

Transitional English 9, 10, 11, 12 ERWC

\*Only one year of an ELD course can be counted for the UC and CSU requirements.

**English 9 (UC and NCAA approved)**  
**English 9 (Transitional) Not NCAA approved**

year long; 5 credits per semester; Grade 9

**Prerequisites:** Student must be in 9<sup>th</sup> grade. Appropriate EL designation required for Transitional enrollment.

English 9 is a college preparatory course that employs the Common Core State Standards to promote the study of the different genres, (novel, short story, drama and poetry), in order to apply critical and analytical thinking skills to the reading of fiction and non-fiction pieces and to the writing of informative, literary response, argumentative, and narrative essays. Students are encouraged to strengthen speaking, listening, vocabulary, study, grammar, word usage, and research skills.

**Honors English 9 (UC and NCAA approved)**  
Grade 9

year long; 5 credits per semester;

English 9 Honors is an intensive course that employs the Common Core State Standards to emphasize the study of different genres (novel, short story, drama and poetry). Students apply critical and analytical as well as abstract thinking skills to the reading of fiction and non-fiction pieces. The composition program further develops command of expository literary response, argumentative, and narrative writing. The class also requires that students extend their reading beyond the literature included in the English 9 curriculum. Students will demonstrate the ability to work independently and build on the mastery of vocabulary, grammar, research and study skills. Students are encouraged to maintain an A or B in the class.

**English 10 (UC and NCAA approved)**  
10

year long; 5 credits per semester; Grade

**English 10 (Transitional) Not NCAA approved**

**Prerequisites:** Student must be in 10<sup>th</sup> grade. Appropriate EL designation required for Transitional enrollment.

English 10 is a college preparatory class that employs the Common Core State Standards to build on the foundation established in ninth grade. The class will emphasize the integration of literature and expository texts, critical thinking and analytical skills, speaking and listening skills. Writing genres include the informal, literary response and argumentative. This course focuses on the significance of various cultural perspectives as presented in each text. The course content is designed to extend study skills enhance organizational skills, develop vocabulary, as well as increase the understanding and recognition of literary devices and literary terminology.

**Honors English 10 (UC and NCAA approved)**

year long; 5 credits per semester; Grade 10

English 10 Honors is an intensive course that employs Common Core State Standards and builds on the foundation of English 9 Honors. The class will further develop and continue to foster close reading strategies. By analyzing elements found in literary texts, students learn to express and support their responses targeting research skills. Writing skills will be reinforced through annotation, analysis and MLA documentation. Analysis, evaluation and synthesis are the critical thinking skills used to engage students when it comes to writing in a variety of forms including expository, argumentative, literary analysis and narrative for different audiences and purposes. The use of language conventions and mechanics of written English, including the rules of grammar and usage, encouraging clear and effective communication. Honors students listen attentively, analyze complex texts, evaluate oral presentations and contribute to class discussions. They also demonstrate an ability to learn independently and to apply academic knowledge to real life situations.

**English 11 (UC and NCAA approved)**  
**English 11 (Transitional) Not NCAA approved**

year long; 5 credits per semester; Grade 11

**Prerequisites:** Student must be in 11<sup>th</sup> grade. Appropriate EL designation required for Transitional enrollment.

English 11 is a college preparatory class that employs the Common Core State Standards to build on the foundation established in ninth and tenth grades. English 11 is a course focusing on the literature of the United States. The curriculum includes American works of literary and historical significance from the eighteenth century through the present, including novels, short stories, poems, and non-fiction selections. Coursework is designed to develop skills including critical reading, annotation, vocabulary development, discussion, research methods, MLA documents, and writing for informative and argumentative purposes.

**Honors English 11** (UC and NCAA approved) year long; 5 credits per semester; Grade 11

English 11 Honors is an intensive course that employs Common Core State Standards and builds on the foundations of English 9 and 10 Honors. English 11 Honors is distinguished by a substantially rigorous and in-depth curriculum, as well as an accelerated pace. English 11 Honors offers balanced content focused on literature, including poetry, writing, and vocabulary study. Students will read a varied selection of fiction and nonfiction works from the American literary periods (early American, Rationalism, Romanticism, Realism, and Modernism). Elements of rhetoric and argumentation are emphasized, requiring students to perform in-depth analysis. Consistent with the rigor of the class, students will be required to work independently on extensive reading, writing, and enrichment assignments, for an hour daily, on average, out of class.

**AP Language and Composition** year long; 5 credits per semester; Grade 11  
(UC and NCAA approved)

AP Language and Composition, an accelerated program, teaches the content of an introductory college survey course. The course focuses on close reading and analysis of literature from varied periods. Students will read essays, letters, speeches, fiction and non-fiction texts from a variety of authors and historical periods. Students will learn to identify an author's purpose and explain the rhetorical strategies used in a text. Writing assignments will emphasize the skills required in the A.P. Language and Composition exam. These include rhetorical analysis, argumentation, and synthesis of information from multiple sources to form a single argument. Consistent with the rigor of the class, students will be required to work independently on a variety of reading and writing assignments, often times out of class.

**English 12** (UC and NCAA approved) year long; 5 credits per semester; Grade 12

**English 12 (Transitional)** Not NCAA approved

**Prerequisites:** Student must be in 12<sup>th</sup> grade. EL designation for Transitional enrollment.

English 12 a course that employs Common Core State Standards and builds on the foundation of English 10 and 11. English 12 teaches standards through three interrelated elements – core literature, the human experience and the process of writing. British Literature is the primary focus with a secondary emphasis on World Literature. Students write literary analysis, argumentative and narrative compositions. The course evaluates shifts that cultural heritage portrays in literature and confronts important human issues.

**Expository Reading and Writing Course (ERWC)** year long; 5 credits per semester; Grade 12

(UC and NCAA approved) ERWC emphasizes the in-depth study of expository and argumentative reading and writing. Students read non-fiction texts grouped into thematic units and then compose written responses to sharpen the skills of comprehension and analysis. Course curriculum was designed by the California State University system to develop the academic literacy skills necessary for success in college and the work of work. With a conditional pass on the EAP (taken junior year) and a "C" or higher in ERWC, CSU schools will grant access to Freshman Composition courses without taking a placement exam. Glendale Community College offers the opportunity to earn similar credit. This course is approved by the UC system as meeting their "b" English requirement.

**AP English Literature** (UC and NCAA approved) year long; 5 credits per semester; Grade 12

AP English Literature is an accelerated program which teaches the content of an introductory college survey course. The course focuses on close reading of challenging literature of varied periods and genres. Writing serves as a tool to convey the students' analyses or interpretations, and students write numerous in-class timed evaluative essays. Students examine and employ the resources of language-connotation, figurative language, irony, syntax and tone.

## ENGLISH LANGUAGE DEVELOPMENT (ELD) DEPARTMENT

The goal for secondary English Language Development (ELD) students is English proficiency. All ELD students receive a sequential English Language Development program based on their diagnosed needs. District approved texts are used along with supplemental materials.

---

### CREDIT REQUIREMENTS:

#### For Burbank Unified School District Graduation Requirements:

- ELD 1
  - Reading – Elective Credit
  - Writing – English Credit
- ELD 2
  - Reading – Elective Credit
  - Writing – English Credit
- ELD 3
  - Reading, Writing & Oral Language – English Credit
- ELD 4
  - Reading, Writing & Oral Language – English Credit

---

### RECOMMENDED COLLEGE PREP COURSES

*Fulfills “b” requirement for UC and CSU*

ELD 3

ELD 4

<b>ELD 1</b>	year long; 2 periods; 2 semesters each; 5 credits per semester, per period; Grade 9-12
--------------	--

**Prerequisites:** Open to novice level English speakers.

This class is a beginning integrated reading/writing-based course aimed at developing basic reading comprehension, thinking skills, and written expression. This course focuses on core content vocabulary and concepts to aid students in accessing core curriculum in math, science, history/social science, Health/Careers, and American culture. Cross-cultural understanding is developed through cooperative learning and other interactive activities.

This course emphasizes all forms of basic communication, beginning with listening to commands and responding physically; answering questions with “yes/no” or one word responses, forming questions and complete statements; and extending communicative competence by writing and performing dialogues, role plays, and skits. Oral communication revolves around essential vocabulary and expressions aimed at providing students with the ability to understand and be understood in everyday situations at the school and local communities, and using English to communicate in socially and culturally appropriate ways.

**ELD 2** year long; 2 periods; 2 semesters each; 5 credits per semester, per period; Grade 9-12

**Prerequisite:** Successful completion of ELD 1, or a score in the upper end of “Novice” on the initial ELPAC.

This two-period block class is an integrated reading/writing-based course which extends communicative, sociolinguistic, and sociocultural competence. The emphasis is on academic vocabulary development, grammatical form and function, written organization skills, reading comprehension, and critical thinking. Oral language skills are developed through role-playing, oral presentation, and theater arts integration.

**ELD 3 (UC approved)** year long; 2 semesters; 5 credits per semester; Grade 9-12

**Prerequisites:** Successful completion of ELD 2, or a score in the lower level of “Intermediate” on the initial ELPAC.

This course is designed for second-language acquisition students. Emphasis is placed on higher level thinking and writing skills, such as compare/contrast, analysis, application, evaluation, and the five-step writing process. Integrated reading, writing, and oral language skills continue to be developed through literature, problem solving, and intercultural communication activities. The course offers credit comparable to English 9.

**ELD 4 (UC approved)** year long; 2 semesters; 5 credits per semester; Grade 9-12

**Prerequisites:** Successful completion of ELD 3, or a score in the upper end of “Intermediate” on the initial ELPAC.

This course is designed for the second-language acquisition students with high academic skills who can still benefit from SDAIE instruction. The curriculum is challenging and meaning-centered and promotes high level thinking skills and cross-cultural understanding. Emphasis continues to be on writing skills, including the five-step writing process. The course offers credit comparable to English 10.

### **Designated ELD**

The purpose of Designated ELD is to provide Long Term English Learners (L-TELS)\* and at-risk for becoming L-TELS\* with the skills and content knowledge to increase their current ELD level and meet reclassification requirements. The course’s academic emphasis is on oral language development, academic vocabulary acquisition, expository writing, and reading comprehension with the use of CA ELD standards in tandem with the State standards for ELA. This course builds student achievement by engaging students in learning tasks that promote academic language through both independent and collaborative work. Students use reading and writing strategies and processes to accomplish a variety of intellectually challenging tasks that promote higher-level thinking. Students will engage in research-based lessons with culminating writing projects and oral presentations.

\*L-TEL: students who have not reclassified after completing five years in U.S. schools. At-risk L-TELS: students who have not reclassified and are not making progress in acquiring English after four years in U.S. schools

## FINE ARTS DEPARTMENT

To ensure that all students develop an appreciation and understanding of the Fine Arts, one year of study in this Department is required for graduation. However, many students are involved with the different offerings for all four years of high school. The Fine Arts program is divided into two sections: Visual Arts and Performing Arts. The goals of the teachers in this Department are to have the arts viewed as a core subject within the District's curriculum, communicate effectively with all parties relevant to the educational process (administration, staff, parents, students, and community), coordinate technology in the courses as it fits into the District's technology plan, and improve articulation with the middle schools which feed into the high schools. These goals will allow the District to realize the full potential of the arts as having a powerful educational influence on the lives of the students enrolled in these courses, as well as those people who view and appreciate the students' fine work.

The Department reflects the diversity of art as a form of entertainment and aesthetic appreciation. Classes are offered to attract the eye (visual arts), the ear (music, both instrumental and vocal), the body (movement and dance), and the mind (dramatic arts). These components are often interwoven, for example, during the production of a musical play. Burbank Unified students have received national recognition for their fine abilities in the performing and digital arts.

---

### CREDIT REQUIREMENTS:

Students must earn at least 10 credits for graduation in fine art.

---

## DANCE

<b>Dance I (UC approved)</b> 12	year long; 5 credits of Fine Arts or P.E. credit per semester; Grade 9-12
------------------------------------	---

**Prerequisites:** None

In this course dancers will explore basic dance technique, which will be applied to several different styles of dance, including modern, ballet, social dance, hip hop, jazz, musical theatre, contemporary, and cultural dance. The art of choreography will also be explored as well as the understanding of correct terminology, body placement, muscle development, dance history, and flexibility. Students will be required to perform in one Dance Concert to fulfill this class. This course is based on the California Dance and P.E. Standards. Proper dance attire will be needed. May be repeated for credit.

<b>Dance II (UC approved)</b> 12	year long; 5 credits of Fine Arts or P.E. credit per semester; Grade 9-12
-------------------------------------	---

**Prerequisites:** Dance I

Dance II is a continuation of the Dance I and dancers will explore basic and intermediate dance technique, which will be applied to several different styles of dance, including modern, ballet, social dance, hip hop, jazz, musical theatre, contemporary, and cultural dance. The art of choreography will also be explored as well as the understanding of correct terminology, body placement, muscle development, dance history, and flexibility. Students will be required to perform in one Dance Concert to fulfill this class. This course is based on the California Dance and P.E. Standards. Proper dance attire will be needed. May be repeated for credit.

<b>Dance III (UC approved)</b> 12	year long; 5 credits of Fine Arts or P.E. credit per semester; Grade 9-12
--------------------------------------	---

**Prerequisites:** Dance I and II

Dance III is a continuation of the Dance I & II and dancers will explore advanced dance technique, which will be applied to several different styles of dance, including modern, ballet, social dance, hip hop, jazz, musical theatre, contemporary, and cultural dance. The art of choreography will also be explored as well as the understanding of correct terminology, body placement, muscle development, dance history, and flexibility. Students will be required to perform in two Dance Concerts to fulfill this class. This course is based on the California Dance and P.E. Standards. Proper dance attire will be needed. May be repeated for credit.

**Dance Production (UC approved)** year long; 5 credits of Fine Arts or P.E. credit per semester; Grade 10-12

**Prerequisites:** Teacher approval. Dance I and Dance II recommended.

Dance Production is designed for students who excel in dance and choreography. In this course dancers will continue to explore intermediate and advanced dance technique, which will be applied to several different styles of dance, including modern, ballet, social dance, hip hop, jazz, musical theatre, contemporary, and cultural dance. Students will study dance terminology, body placement, muscle development, and flexibility. Performances, choreography, staging, costuming, and stage craft will be a large portion of this course. Students in Dance Production are expected to create choreographic material that will be performed in two large performances during the school year. The student must maintain a designated grade point average to perform. Proper dance attire will be needed. The California Dance Standards are fulfilled during the course of the year. May be repeated for credit.

**Color Guard/Winter Guard** year long; 5 credits of Fine Arts or PE credit per semester; Grade 9-12

**Prerequisites:** Students are admitted by audition only.

Color Guard students will meet during the Marching Band period first semester and will compete along with the Marching Band. Winter Guard students, comprising a competitive performance group in which basic equipment technique is learned, perform the season show and will compete against other schools at local winter guard association shows.

Color Guard offers the student an opportunity to learn basic dance and conditioning techniques that are taken from Ballet, Jazz, Modern Dance and Military Drill. The student is also educated in how to recognize, treat, and prevent common sports injuries such as sprained ankles, tendonitis, and sore muscles. The student is given an opportunity to develop technical skills and the vocabulary that comes from dance and equipment (flag, rifle, sabre) as well as developing skills of composition, musical interpretation and performance. Students are introduced to the elements of team building, problem solving, spatial awareness and maneuvering, conflict resolution, and spectator etiquette. Dance clothing and uniforms must be purchased. The student must maintain a designated grade point average to perform.

## DRAMATIC ARTS – FINE ARTS CREDIT

**Drama I (UC approved)** year long; 5 credits per semester; Grade 9-12

**Prerequisites:** None.

Drama I is the introductory course of the drama program. During the two semesters of the class, students will explore several aspects of the theatre arts including improvisation, acting, script-writing, directing, technical



theatre, theatre history and literature and how to critically analyze a script or performance. This course may be repeated for credit.

---

**Drama II (UC approved)** year long; 5 credits per semester; Grade 9-12

---

**Prerequisites:** Completion of Drama I with a grade of “B” or higher (recommended); admittance approval by instructor (required); an audition may be required. This course may be repeated for credit.

Drama II is the intermediate theatre course of the drama program. Designed to go beyond the needs of the general student, the instructor will only admit students into this class who are deemed to be capable of more advanced theatrical work. During the two semesters of the class, students will study the many aspects of the theatre arts in greater depth and detail than in Drama I. An emphasis will be placed on developing the student’s acting performance skills.

---

**Play Production (UC approved)** year long; 5 credits per semester; Grade 9-12

---

**Prerequisites:** Completion of Drama II with a grade of “B” or higher recommended); admittance approval by instructor (required); an audition may be required. This course may be repeated for credit.

Play production is the advanced theatre course of the drama program. Designed for only the most accomplished and dedicated theatre student, this two-semester class is all about applying what the student has learned in the earlier drama courses in the program to actually producing and performing theatrical presentations for the public. Many hours of work outside of class are required. This course may be repeated for credit.

---

**Musical Theater (UC approved JBHS only)** year long; 5 credits per semester; Grade 9-12

---

**Prerequisites:** None.

Students will study the evolution of the American musical and analyze how the different elements of music, lyrics, voice, and movement come together to create characters and story. All choirs include choreography. Students will participate in acting and directing of musical theater selections for classroom performances.

---

**Stagecraft Technology (UC approved)** year long; 10 credits of Fine Arts/Practical Arts Credit per semester.

---

**Prerequisites:** None.

This class is intended for students interested in pursuing a career in the production and/or technical side of theatre or film. Set design and construction, lighting design and theory, light board operation, sound design and theory, sound recording and mixing, projection systems, rigging systems, and stage management are explored. Each student will demonstrate the safe execution of technical production work in a variety of disciplines, and may choose to specialize and get advanced training/experience in those areas. Students are expected to work hard to meet production deadlines. Career growth and leadership/soft-skills are also developed. The end product of the students’ work is over two dozen live theatre productions for various performing arts disciplines, the school, and the community each year. Students benefit from opportunities to work alongside and learn from industry professionals, visit and perform in other theatrical venues, and learn about career pathways after high school.

## INSTRUMENTAL MUSIC – FINE ARTS/ELECTIVE

---

**Concert Band (UC approved)** year long; 5 credits per semester; Grade 9-12

---

**Prerequisites:** Minimum one year instrumental music study.

The concert band typically consists of freshmen and sophomores. Students in the concert band play music appropriate to their level of study. They explore a variety of literature for concert band while developing musical skill and technical facility. Students in the concert band will perform in 3-5 local concerts and festivals annually. Students should be prepared to practice outside of class individually and in sectionals. All students enrolled in the concert band are expected to enroll in marching band. The concert band is supported by BUSD and the IMA.

---

<b>Jazz Band (UC approved)</b>	5 credits per semester; Grade 10-12
--------------------------------	-------------------------------------

---

**Prerequisites:** Student must play an appropriate jazz band instrument, i.e., Saxophone, Trumpet, Trombone, Piano, Guitar, Bass, Drums/Percussion, or other instruments as needed. Student must be able to read music and perform on their jazz band instrument and must successfully pass an entrance audition. Students must have the permission of the instructor to participate in jazz band. Students must be concurrently enrolled in the corresponding music performance class during the school day: i.e., String Orchestra for Strings, Concert Band or Wind Ensemble for Winds, Brass, and Percussion. Exceptions may be made at the sole discretion of the instructor for students who play instruments that are not part of the regular school day course offerings.

Jazz Band explores the rich heritage of Jazz music from all time periods through regular rehearsals and performances aspiring to the highest standards. It provides students a unique opportunity to learn about, rehearse and perform repertoire of the greatest musical and historical significant in a full big band setting. It also teaches students about the importance of Jazz as an American art form.

---

<b>Marching Band (UC approved)</b>	year long; 5 credits of Elective/Fine Arts credit; P.E. credit; Grade 9-12
------------------------------------	--

---

**Prerequisites:** Minimum 1 year instrumental music study and concurrent enrollment in concert band, symphonic band, wind ensemble, dance team and color guard.

Members of the marching band perform at some home football games, local parades, and field shows. All students in the marching band will perform in parades; selected students will perform in field shows. This class meets outside of the school day to maximize facilities during the fall semester only. The marching band is supported by BUSD and IMA.

---

<b>Orchestra (UC approved BHS only)</b>	year long; 5 credits per semester; Grade 9-12
---	---

---

**Prerequisites:** Previous experience on violin, cello, or bass, or instructor's approval.

The Orchestra is comprised of string players who perform at an intermediate or advanced level with one or more years of participation in middle school and/or elementary school, although beginners can participate with teacher approval. This class is designed to provide a high level of participation while promoting a greater understanding of orchestral music. The Orchestra will perform as a String Ensemble and will join with wind and percussion players to form the Symphony Orchestra.

---

<b>Symphonic Band (UC approved)</b>	year long; 5 credits per semester; Grade 10-12
-------------------------------------	--

---

**Prerequisites:** Minimum 2 years instrumental music study and director recommendation

The Symphonic Band performs at an intermediate level, usually with two or more years of participation at the middle or high school level. Typically, the Symphonic Band consists of sophomores and juniors. Students in the Symphonic Band should be prepared to practice outside of class rehearsal and perform in 4-6 local concerts

annually. All students enrolled in the Symphonic Band are expected to enroll in the marching band. Students in the Symphonic Band explore the varied repertoire for wind bands and perform in small ensembles. The Symphonic Band is supported by BUSD and the IMA.

---

**Wind Ensemble (UC approved)**

year long; 5 credits per semester; Grade 10-12

---

**Prerequisites:** Minimum 4 years instrumental music study and audition

Members of the Wind Ensemble are selected by audition only for extremely limited seating. Wind Ensemble students perform at 6-10 concerts and festivals and tour bi-annually. This course is designed to provide the highest level of performance opportunity available to high school students. As such, students can expect additional practice time outside of class in the form of personal practice and sectionals. All students enrolled in the Wind Ensemble are expected to enroll in the marching band. The Wind Ensemble is supported by BUSD and the IMA.

## VOCAL MUSIC – FINE ARTS/ELECTIVE CREDIT

---

**All vocal music classes may be repeated for credit with the approval of the instructor.**

<b>Chamber Choir (UC approved)</b>	year long; 2 periods; 5 credits per period per semester; PE Credit, Grade 9-12
------------------------------------	--

**Prerequisites:** Successful completion of Treble Choir, Mixed Choir, Madrigals, and/or audition. Concurrent enrollment in Show Dance (JBHS only).

This advanced choir studies all genres of music from significant historical eras and in original languages as well as musical theatre and pop. The choir participates in occasional community performances, classical festivals and home concerts. Students are eligible to audition for solos in major productions like Pop Show.

<b>Madrigal Choir (UC approved)</b>	year long; 5 credits per semester; Grade 9-12
-------------------------------------	---

**Prerequisites:** Successful completion of Treble Choir, Mixed Choir, and/or audition.

This advanced choir studies all genres of music from significant historical eras and in original languages as well as musical theatre and pop. The choir participates in occasional community performances, classical festivals and home concerts. Students are eligible to audition for solos in major productions like Pop Show.

<b>Mixed Choir (UC approved)</b>	year long; 5 credits per semester; Grade 9-12
----------------------------------	---

**Prerequisites:** Audition.

This intermediate choir studies all genres of music from significant historical eras and in original languages as well as musical theatre and pop. The choir participates in occasional community performances, classical festivals and home concerts. Students are eligible to audition for solos in major productions like Pop Show.

<b>Treble Choir (UC approved)</b>	year long; 5 credits per semester; Grade 9-12
-----------------------------------	---

**Prerequisites:** Audition.

This intermediate choir studies all genres of music from significant historical eras and in original languages as well as musical theatre and pop. The choir participates in occasional community performances, classical festivals and home concerts. Students are eligible to audition for solos in major productions like Pop Show.

## VISUAL ARTS

---

<b>Art Structure I (UC approved)</b>	year long; 5 credits per semester; Grade 9-12
--------------------------------------	---

**Prerequisites:** None.

This is a sequence-based beginning course that explores the fundamentals of drawing and the elements of art (line, value, texture, shape, and form). Students will create in a variety of media while they learn about linear perspective, value, and creating three-dimensional forms on a two-dimensional surface. They will participate in the creation of

realistic, representational, and some non-objective works of art from observation and imagination. Instruction will include use of pencil, ink, paint, charcoal/chalk, and colored pencils. Art survey of artists and their works will be periodically explored.

**Art Structure II (UC approved)**  
12

year long; 5 credits per semester; Grade 9-

**Prerequisites:** Successful completion of Art Structure I and art teacher approval.

This instruction will emphasize color theory, organization, composition, and manipulation of the elements of art through two-dimensional design experiences. Instruction will also include the use of various media (pencil, colored pencil, ink and paint) while working with subject matter realistically and abstractly, culminating in a final painting project. Art survey of artists and their works will be periodically explored.

**Advanced Art Structure (UC approved)**

year long; 5 credits per semester; Grade 9-12

**Prerequisites:** Successful completion of Art Structure I and II or Art teacher approval.

Instruction will focus on more in-depth and high-level lessons covering the areas from art A and B Art Structure I and II. It will further explore drawing, color application, composition and the elements of art through representational and abstract art projects. Students will use a wide variety of media, mixed media and techniques throughout the course. Each class will include a survey of various artists, their techniques, and works through the ages. This class may be repeated for credit.

**Art History (UC approved BHS Only)**

year long; 5 credits per semester; Grade 10-12

**Prerequisites:** None.

Art History is a comprehensive course that explores art history and visual literacy throughout time and world cultures, focusing on the evolution of art traditions. Students participate in daily discussions, analysis, written assignments, and research projects, as well as some hands-on art production. This course is lecture based and student participation is critical. By the end of the course students will demonstrate an understanding of the history of Western civilization through art traditions still present in our contemporary culture. Students will understand how non-Western cultures and media play a constant and significant role in our everyday experience. This course reinforces the concepts and practices covered in history, social studies, and language arts classes taken throughout high school.

**AP Studio Art (UC approved)**  
12

a year long; 5 credits per semester; Grade 10-

**Prerequisites:** Completion of Art Structure I and II and Advanced Art Structure or Art teacher approval.

This course will prepare more serious students to take the advanced placement examination in Studio Art: A Drawing Portfolio consists of works produced in areas of breadth and concentration, exploring various subject matters and media. This course begins in the spring of the Advanced Art course and culminates in a year of focused art production. The AP student must be prepared to complete further work on his/her own at the college level to supplement the classroom instruction. The AP Studio Art exam given in the spring is mandatory. Students who do not submit a Studio Art Portfolio to AP will not receive the weighted grade point.

**Animation I: Animation Fundamentals (UC approved; BHS only and CTE)**

year long; 5 credits per semester; Grade 9- 12

**Prerequisite:** None. Art Structure 1 highly recommended.

Animation I provides experiences in traditional and contemporary techniques for designing and creating the illusion of movement. This class is developed for the interested and untrained student, but drawing experience or completion of Art Structure I is *highly recommended* as exercises and projects are heavily drawing-focused. Students will learn to design characters, backgrounds and graphic images, sequence original concepts on storyboards, and create original animated shorts using a variety of software and methods. The curriculum includes the study of the animation process, practice of the Principles of Animation, criteria for analyzing and interpreting animated images, survey of animation history, overview of careers in the field of Animation, and development of personal concepts and artistic skills.

---

<b>Animation II: Advanced Animation (not UC Approved) (BHS only and CTE)</b>	year long; 5
credits per semester; Grade 9- 12	

---

**Prerequisites:** Animation I with a minimum grade of C (B or above recommended)

Animation II builds on Animation I experiences in traditional and contemporary techniques for designing and creating the illusion of movement, plus focused, independent focus work each semester, based on student artistic and technical interests. Emphasis is placed on developing personal concepts and artistic skills to build a strong and diverse portfolio. Students will initiate and visualize ideas for sophisticated animated shorts or illustrated stories, and create original characters and imagery to clearly convey story or message. Students are encouraged to develop independent art habits, with choice in subject, techniques and medias for sketchbook and portfolio work.

---

<b>Animation III Entertainment Design(UC approved; BHS only and CTE)</b>	year long; 5
credits per semester; Grade 9- 12	

---

**Prerequisites:** Animation 2 with a minimum grade of C (B or above recommended)

Animation III builds on Animation I & 2 fundamentals in character and concept development and the illusion of movement, with a focus toward digital content creation for entertainment. Students will develop and plan out interactive concepts, explore digital applications that will enable them to visualize and/or animate prototypes, and complete an independent focus project. Emphasis is placed on developing personal concepts and artistic skills to build a strong and diverse portfolio/demo reel. Students will continue independent art habits, with choice in subject, techniques and medias for sketchbook and portfolio work.

---

<b>Digital Art/Video Production (UC approved)</b>	year long; 5 credits per semester; Grade 9-
12	

---

**Prerequisite:** None

Utilizing a variety of teaching strategies, this course introduces students to the history of motion pictures. It provides them with an understanding of a variety of cinematic techniques, and offers them opportunities to write, discuss, and apply to original video projects, the knowledge and techniques gained. Through lecture, reading, discussion, and analysis of professional examples, students learn the elements of cinema and gain an understanding of American culture. Using digital video camcorders and audio/video editing software, students create original video projects in a number of genres (e.g., public service announcements, documentaries, and feature short films). Students critique their work using appropriate cinematic and art vocabulary.

**Advanced Digital Art/Video Production (not UC approved)**  
semester; Grade 9- 12

year long; 5 credits per

**Prerequisites:** Digital Art/Video Production 1

Furthering their study of American culture through cinema, this course focuses on particular cinematic genres. Students learn to express their ideas cinematically through a variety of film projects, including silent features, music montages, documentary films, and feature short films. This course continues where Digital Art/Video Production leaves off by providing students with a deeper understanding of the audio/video software used to create their films.

Students critique their work using appropriate cinematic and art vocabulary.

**Digital Media Production (UC approved)**  
12

year long; 5 credits per semester; Grade 9-

Students will learn to write, storyboard, act in, and edit videos for the internet and the screen. Their art will be the visual story. This entry level course provides the foundational skills needed to enter the television production industry. The class provides an overview of the equipment, job responsibilities, and techniques involved in both traditional studio production and remote location work with an emphasis placed on the digital technology. Emphasis is placed on vocabulary and correct industry terms, camera operation, picture composition, script writing, lighting, remote shooting, directing, and the editing process. The foundations of acting, stage management, editing in programs such as Adobe Premiere, After Effect, or other editing software will be taught.

**Advanced Digital Media Production (UC approved)**  
Grade 9- 12

year long; 5 credits per semester;

**Prerequisites:** Teacher recommendation or Digital Media Production.

Students will learn to write, storyboard, act in, and edit videos for the internet and the screen. Their art will be the visual story. Students will be given opportunities to create stories and videos for businesses and nonprofit organizations. This course provides the advanced skills needed to enter the television production industry. The class provides an in depth look at the equipment, job responsibilities, and techniques involved in both traditional studio production and remote location work with an emphasis placed on the digital technology. Emphasis is placed on vocabulary and correct industry terms, camera operation, picture composition, script writing, lighting, remote shooting, directing, and the editing process. This is an advanced class that builds on student's prior knowledge of acting, stage management, editing in programs such as Adobe Premiere, After Effect, or other editing software.

**Digital Media Production Directors Cut (UC approved, JBHS only)**  
credits per semester; Grade 9- 12

year long; 5

**Prerequisites:** Teacher recommendation or Advanced Digital Media Production.

Building on students knowledge from prerequisite courses, students will refine and improve their skills of writing, storyboarding, acting, and editing videos for the Internet and the screen. Their art will be the visual story. Students will be given opportunities to create stories and videos for businesses and no- profit organizations. This course provides the advanced skills needed to enter the television production industry. The class provides an in depth look at the equipment, job responsibilities, and techniques involved in both traditional studio production and remote location work with an emphasis placed on the digital technology. Emphasis is placed on vocabulary and correct industry terms, camera operation, picture composition, script writing, lighting, remote shooting, directing, and the editing process. This is an advanced class that builds on students' prior knowledge of acting, stage management, editing in programs such as Adobe Premiere, After Effect, or other editing software.

**Broadcast Journalism (UC approved)**  
12

year long; 5 credits per semester; Grade 10-12

**Prerequisites:** Teacher recommendation or Video Production 1.

This course will provide students with the skills and technical abilities to run a studio in a live news broadcast environment. Emphasis will be placed on communication skills, professionalism, responsibility, and teamwork. Students will learn to work equipment appropriately and produce a variety of video projects to air on the program.

**Advanced Broadcast Journalism**

Year long; 5 credits per semester; Grade 10-12

**Prerequisite:** Broadcast Journalism

Students will write, pitch ideas, film, and produce a daily news show as a part of the school announcements show. Additionally, they will learn the proper techniques in interviewing, stand-up reporting and creating news packages based on events and activities going on around campus. This advanced course provides the basic skills needed to enter the television production industry. It provides an overview of the equipment, job responsibilities, and techniques involved in both traditional studio production and remote location work. Emphasis is placed on vocabulary and correct industry terms, camera operation, picture composition, script writing, lighting, remote shooting, directing, and the editing process. This advanced class builds on students' prior knowledge of acting, stage management, editing in programs such as Adobe Premiere, After Effects, and other editing software. Students will learn to analyze the aesthetic value of a variety of news shows as well as their own broadcasts and mini shows and will learn to bring that into their own productions and news packages.

**Sculpture I (UC approved)**

year long; 5 credits per semester; Grade 9-12

**Prerequisite:** None

Sculpture I provides experiences in classical and contemporary three-dimensional art methods in a variety of media, with an emphasis on the elements and principles of design. The curriculum includes the study of aesthetics, creative expression and symbolism, criteria for analyzing and interpreting works of art, and advancement of personal artistic skills. Students will focus on realizing a strong design, originality and craftsmanship while learning the sculptural techniques, styles and tools needed to build successful dimensional works of art.

**Sculpture 2 (not UC approved BHS only)**

12

year long; 5 credits per semester; Grade 9-12

**Prerequisite:** Sculpture I with minimum grade of B

Sculpture II builds on Sculpture I experiences in classical and contemporary three-dimensional art methods, plus focused independent work based on student interest in media and skill development. Emphasis is placed on realizing original, well designed and symbolic concepts, sophisticated use of materials, and the development of a personal style in order to build a high-quality portfolio of sculptural works



## PHOTOGRAPHY

---

**CADD Computer Aided Design and Drafting (UC approved BHS Only)**  
credits per semester; Grade 9- 12

year long; 5

The course will focus on drafting principles and Computer Aided Design (CAD), the foundation application that will be used to create 3D models and assemblies. All students should have completed or be currently enrolled in Geometry as a prerequisite. This is an appropriate course for any student who may pursue a career in industrial design, manufacturing or engineering technology. Students will construct various advanced drawings using CAD software. The student will be doing a wide range of assemblies and students will further their skills in advanced solid modeling. Relations are used to define attributes such as tangency, parallelism, perpendicularity and concentricity with respect to sketch geometry. The student will understand that the assembly mates define equivalent relations with respect to the individual parts or components, allowing the easy construction of assemblies.

**Digital Photography I (UC approved BHS Only)**  
12

year long; 5 credits per semester; Grade 9-

The course develops competency in the digital darkroom through lessons and projects that teach photography and Photoshop skills. Students will also learn basic color theory and the fundamentals of image processing. These skills will then be applied to developing an expressive visual language using digital imaging. The goal of the class is to make each student competent in the conceptual, aesthetic and technical aspects of digital photography and Photoshop.

**Digital Photography II (BHS Only)**  
12

Year long; 5 credits per semester; Grade 9-

The course applies advanced digital darkroom skills through lessons and projects that emphasize DSLR photography and intermediate to advanced Photoshop skills. Students will show an understanding of photography and digital composition with narrative, and non-objective images. These skills will then be applied to developing an expressive visual language using digital photography and constructed composites using Photoshop. The goal of the class is to make each student highly skilled in the conceptual, aesthetic and technical aspects of digital photography and Photoshop.

**Photo I (UC approved)**  
12

year long; 5 credits per semester; Grade 9-

**Prerequisites:** None.

First semester is basic, but extensive, using a hands-on approach. Students will learn to operate a camera and shoot, develop, contact print, enlarge and finish their own work. They will learn techniques and compositional values of still photography. Students may need an automatic or manual 35mm camera. 4x5 studio view cameras will be introduced for studio assignments. Second semester focuses on advanced shooting techniques and darkroom assignments. A full range of photography experiences will be covered. Studio photography, special effects, landscapes, and fine art assignments will be given to round out the students' skills. Color photography will be introduced, with both film processing and printing. Digital imaging of film will be introduced.

**Photo II (UC approved)**  
12

year long; 5 credits per semester; Grade 10-

**Prerequisites:** Completion of Photo I

Students will work individually to produce their own personalized photography portfolios. Artistic and technical abilities will be refined. Portfolio work will be used to enter photographic competitions, apply to art schools, or show to potential employers. May be repeated for credit.

**Yearbook Design (UC approved)**

year long; 5 credits per semester; Grade 9-

12

**Prerequisites:** None

Yearbook is a year-long class that allows students to learn and develop technical and creative skills in photography, writing, editing and design layout along with business skills in organization, marketing, and deadline-driven planning. The ultimate goal every year is for the staff members to couple these skills and techniques with their artistic and organizational talents and work as a team in order to produce an exceptional record of John Burroughs High School staff and students. Yearbook students will achieve mastery of visual arts and publication design and the terms, processes, and skills that accompany these mediums. Meeting yearbook goals and objectives, caring for special equipment/supplies inherent to the program, meeting specifically assigned tasks by predetermined deadlines will also be fundamental in this course. The ability to work together, ability to celebrate differences among staffers, ability to listen and to speak up, and ability to have fun and enjoy victories both big and small will be needed for a successful year. Each yearbook staff member will be responsible for not only mastering the theory associated with the yearbook but also applying those acquired skills towards the production of the yearbook. Students will apply design and editing principles learned throughout the year and utilize them in order to drive the visual and verbal themes developed in the book. To most closely match a professional publication staff, students will operate within a hierarchy of staff members who report to their peers. It is important for both yearbook staff members and parents to understand this system. Peers will hold students accountable, and in some situations editors may address concerns with individual staffers in the same manner a teacher/employer might conference with students/employees.

## WORLD LANGUAGES DEPARTMENT

Authentic communication is the main goal and activity in all World Language courses. Students read, write, speak, listen, and sign the target language on a regular basis. Teachers balance the instruction of grammar details with the extended practice required for students to acquire and produce language in an increasingly authentic way, therefore class time emphasizes consistent practice in the target language using a variety of methods and techniques. Per state standards, students also learn about and appreciate other cultures. The UC and CSU systems require two years of a single foreign language during high school; however, both systems recommend three. The World Language department strongly encourages students to take four years of a world language in order to develop fluency, prepare for college-level coursework, and gain the rewards of bilingualism.

Students who are interested in taking Honors or Advanced Placement (AP) courses should be those students with proven academic achievement as evidenced by superior prior grades, especially in the target language. In addition, students may be asked for an on-demand writing sample or conversational interview to evaluate the ability in the AP language of their choice. Potential Honors/AP students should be organized, responsible and able to manage a difficult course load. They should also be academically focused and interested in studying topics more rigorous and in more depth. If a student wants additional information about Honors/AP courses, he or she should consult with the high school guidance counselor or the specific AP teacher of their language choice.

### Graduation Requirements

World Language is not required for graduation from high school.

---

### COLLEGE ENTRANCE FOR UC/CSU REQUIREMENTS

2 years of a single foreign language are required for UC/CSU entrance. 3 years are recommended.

---

### RECOMMENDED COLLEGE PREP COURSES:

*Fulfills the "e" for UC and CSU*

French 1, French 2, French 3

AP French 4

Spanish 1, Spanish 2, Spanish 3

AP Spanish Language 4, AP Spanish Literature 5

Spanish for Spanish Speakers 1, Spanish for Spanish Speakers 2

American Sign Language 1, American Sign Language 2, American Sign Language 3

---

### **American Sign Language 1 (UC and NCAA approved)**      year long; 5 credits per semester; Grade 9-12

This course is an introduction to the understanding and use of American Sign Language. Students will develop receptive and expressive skills in the target language. Coursework will consist of classroom activities and independent practice communicating about family and friends, activities in and out of school, daily routines, exchanging personal information, discussing living situations, and they will be able to count to 100. Students will identify and use appropriate sign and non-manual markers for WH and Yes/No questions, English conjunctions, distance, listing and time. Fingerspelling will be introduced as well as exposure to the values, beliefs, and behaviors of people within Deaf culture. Use of American Sign Language for instruction and learning will increase progressively throughout the year.

**American Sign Language 2 (UC and NCAA approved)** year long; 5 credits per semester; Grade 9-12

**Prerequisites:** Completion of ASL 1 or pass equivalency test.

Students will increase visual-gestural skills through the use of more complex grammatical and cultural concepts. Course includes conversation strategies, grammar analysis, vocabulary and idiom development and will be taught primarily in the target language. Students will increase cultural awareness and learn cross-cultural adjustment skills.

**American Sign Language 3 (UC and NCAA approved)** year long; 5 credits per semester; Grade 9- 12

**Prerequisites:** Completion of ASL 2.

Students will increase their receptive and expressive skills toward gaining fluency in American Sign Language through the use of lecture, videotape, conversation, analysis of grammar and vocabulary, and idiom development. Further studies of the Deaf Community and culture specifically related to political and current community issues will be included. The course will also introduce the students to the basic skills and ethics required of an interpreter and what career paths could be available to them. Course will be taught in American Sign Language.

**French 1 (UC and NCAA approved)** year long; 5 credits per semester; Grade 9-12

Students learn the basic building blocks of language to immediately begin communicating about personal matters such as friends, family, activities, and school. Reading, listening, speaking and writing complement each other to develop a sense of phonetics and syntax in French. Cultural readings introduce students to the francophone world. Students are able to carry on unmemorized short dialogs, mostly in the present tense, and to write short paragraphs to describe their lives and subjects very familiar to them. We place an emphasis on trying to teach the students to think in French from the start and develop fluency at least in areas most familiar to them.

**French 2 (UC and NCAA approved)** year long; 5 credits per semester; Grade 9-10

**Prerequisites:** Completion of French 1 with a C or higher.

Students learn additional grammar and verb tenses in order to narrate events in the past and predict future life situations. Topics of communication also expand to include the arts, travel, geography, sports, medicine and other topics. Through continued extension of the four main modalities, students further their ability to think in French using French syntax and idioms. Culture is more deeply explored and reading texts grow in length, offering students an opportunity to synthesize their cultural knowledge through various sources. Listening comprehension becomes more sophisticated, and students are able to speak for minutes at a time and write multi- paragraph texts.

**French 3 (UC and NCAA approved)** year long; 5 credits per semester; Grade 11-12

**Prerequisites:** Completion of French 2 with a C or higher.

Students review and complete their studies of nearly all of the grammar components of the language and address many more topics of communication beyond their personal lives such as historical events, geopolitics, literature, science and others. Communication becomes increasingly broad in topic and flexible in terms of time

references, with students using many tenses in a sentence including conditional, past conditional and future conditional. Students develop their sense of pragmatics and practice speaking and writing to different kinds of audiences in an appropriate register.

---

**AP French (UC and NCAA approved)** year long; 5 credits per semester; Grade 11-12

---

**Prerequisites:** Completion of French 3 with a C or higher.

Students master the forms of the language with great consistency and extend the topics on which they can both prepare presentational language as well as expound extemporaneously. Synthesis of information from multiple texts and analysis of the quality of the texts (or other form of communication be it video or audio) is practiced.

Listening comprehension exercises are from authentic sources and not textbook related materials, and study of the francophone world is extensive. This course prepares students to pass the AP Language and Culture Exam given in the spring.

---

**Spanish 1 (UC and NCAA approved)** year long; 5 credits per semester; Grade 9-12

---

**Prerequisites:** None

Students will develop skills in listening, speaking, reading, and writing in the target language, as well as acquiring the ability to function in the world where Spanish is spoken. Coursework will consist of classroom activities and independent practice communicating about family and friends, community, school and personal preferences. Use of Spanish for instruction and learning will increase progressively throughout the year. This class is not intended for those who already possess primary skills in Spanish.

---

**Spanish 2 (UC and NCAA approved)** year long; 5 credits per semester: Grade 9-12

---

**Prerequisites:** Completion of Spanish 1 with C or higher.

This course continues to develop the 4 modalities of secondary language acquisition. It places daily emphasis on authentic use of language and introduces various verb tenses (specifically narration) for students to increase their skills in communication. The course will be conducted primarily in Spanish and students are expected to use Spanish as their primary language in class. By the end of the class, students will be writing composition-level samples and participating in conversations with intermediate fluency.

---

**Spanish 3 (UC and NCAA approved)** year long; 5 credits per semester; Grade 11-12

---

**Prerequisites:** Completion of Spanish 2 with a C or higher.

This course builds on the foundation of the first two years of vocabulary, conversation, and grammar. All verb tenses will be studied and utilized in this course. The course will be conducted entirely in Spanish and student participation in the target language is expected at all times. This course is considered an Honors-level class based on the outside work required and the instructional design of the classroom. In this curriculum, students will develop their language skills to a level that will help prepare them for independent use of the language outside the classroom or for the Spanish AP class.

---

**AP Spanish Language and Culture (UC and NCAA approved)** year long; 5 credits per semester; Grade 10-12

---

**Prerequisites:** Completion of Spanish 3 or Spanish for Spanish Speakers 2 with C or higher both semesters.

This course is for students who wish to develop proficiency and integrate their language skills, using authentic materials and sources. Strong skills of listening, speaking, reading, and writing in Spanish are required. Students will be expected to speak in response to oral questions, listen for comprehension, write essays with an analytic point of view, and master advanced Spanish grammar. This course is geared to the expectation that the student will pass the mandatory AP Spanish Language exam given in the spring. Students who do not take the AP exam will not receive the weighted grade point for either semester the class is taken.

**AP Spanish Literature (UC and NCAA approved)** year long; 5 credits per semester; Grade 11- 12

**Prerequisites:** Completion of AP Spanish 4 or Spanish for Spanish Speakers 2.

This is the equivalent of a second-year college introduction to literature course in Spanish, covering selected works from the literature of Spanish speaking countries. Students will learn to understand lectures and participate actively in discussions on literary topics, both in Spanish; will be able to do a close reading of literary texts of all genres in Spanish; and will analyze critically the form and content of literary works (including poetry) orally and in writing, using appropriate terminology.

**Spanish for Spanish Speakers 1 (UC and NCAA approved)** year long; 5 credits per semester; Grade 9-12

**Prerequisites:** Must be a native Spanish speaker (or at least speak Spanish at home).

This class is open to native speakers who wish to improve their language skills (speaking, listening, reading, and writing), and improve spelling as well as grammatical skills. These skills will be developed through thematic units dealing with such topics as literature, history, and geography.

**Spanish for Spanish Speakers 2 (UC and NCAA approved)** year long; 5 credits per semester; Grade 9-12

**Prerequisites:** Completion of Spanish 1.

This class is an enriched two-semester course for Spanish Speakers who have successfully completed Spanish for Spanish Speakers 1. It focuses on developing students' abilities in reading, writing, language conventions, improving their conversational skills and expanding their vocabulary in many themes and for diverse audiences. It also covers the culture and history of Latin America and other interdisciplinary themes in science, technology, art, film, music, current events and the environment.

Students will read longer and more sophisticated texts of fiction and non-fiction, they will produce diverse samples of creative and academic writing based on authentic works by famous Hispanic authors. This class offers a unique opportunity to raise students' awareness of the importance of their linguistic and cultural heritage within a pluralistic contemporary American society. This course is completely in Spanish.

MATHEMATICS DEPARTMENT

9<sup>th</sup> Grade  
Grade

10<sup>th</sup> Grade

11<sup>th</sup> Grade

12<sup>th</sup>

All sequences include a four-year plan for mathematics. Solid lines indicate standard or recommended sequences. Dashed lines indicated non-standard or alternate sequence possibilities.

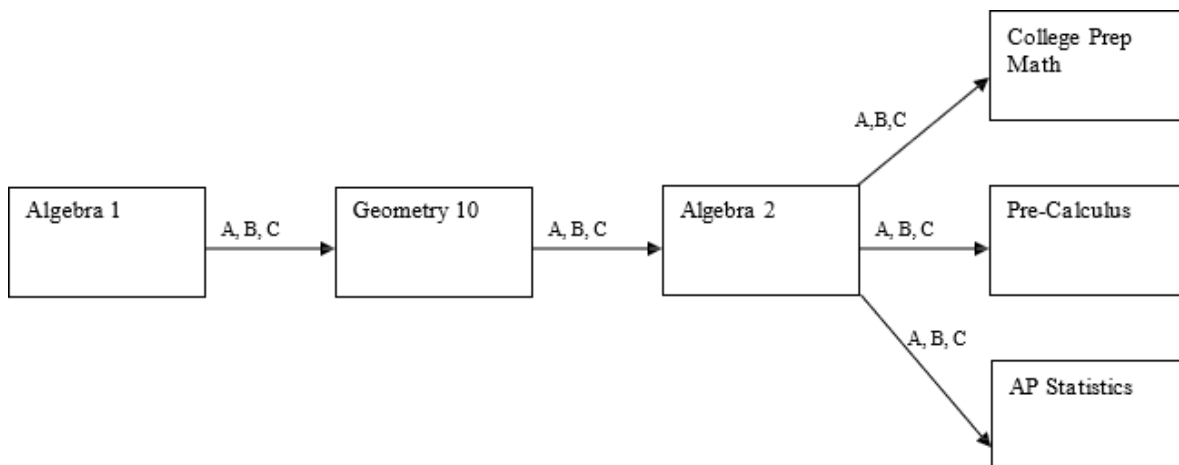

If the student earns a C grade first semester and a D grade second semester, it is recommended that the student take summer school or repeat the course.

Grade

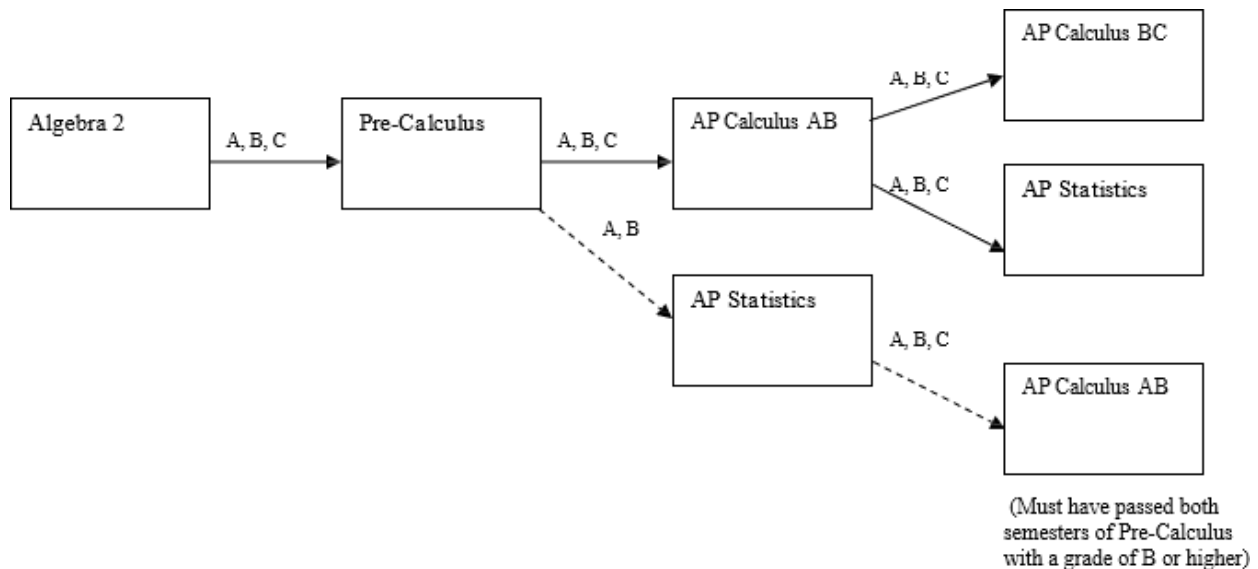
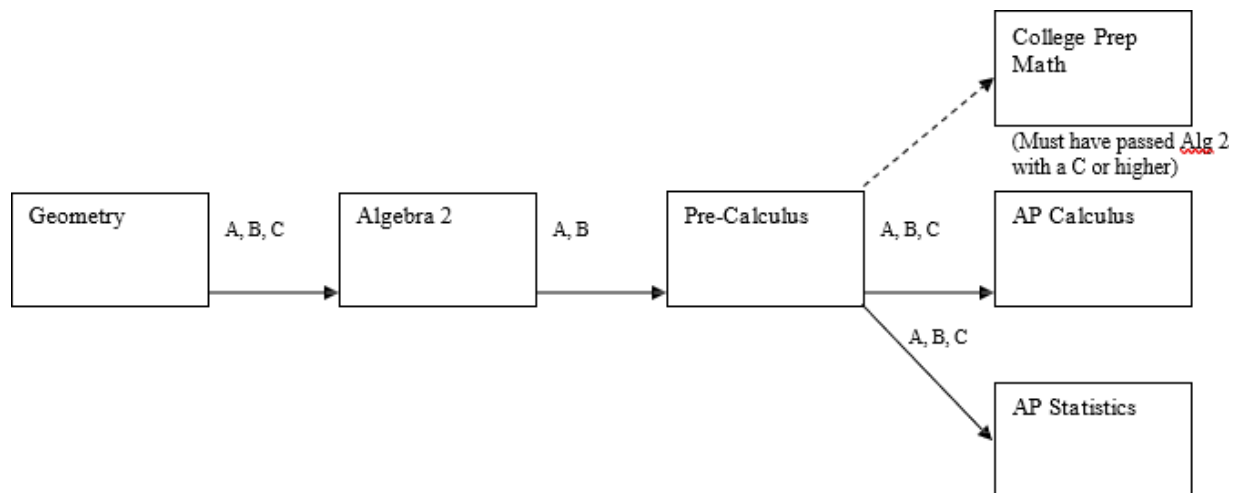
10<sup>th</sup> Grade11<sup>th</sup> Grade12<sup>th</sup> Grade

If the student earns a C grade first semester and a D grade second semester, it is recommended that the student take summer school or repeat the course.

The Burbank Unified School District requires 20 semester units of mathematics for graduation. Algebra 1 or its equivalent must be completed for graduation. The University of California and California State University systems both require a minimum of three years of college preparatory math courses--specifically, Algebra, Geometry and Algebra 2 -- for entrance. A fourth year of college prep math is recommended. Entering 9<sup>th</sup> graders are placed in math classes on the basis of their eighth grade



standardized test scores, and performance in the 8<sup>th</sup> grade math class.

Students who are interested in taking Honors or Advanced Placement (AP) courses should be those students with proven academic achievement as evidenced by superior prior grades, and outstanding performance on District Common Assessments. Potential Honors/AP students should be organized, responsible and able to manage a difficult course load. They should also be academically focused and interested in studying topics more rigorously and in more depth. If a student wants additional information about Honors/AP courses, he or she should consult with the high school guidance counselor.

---

## GRADUATION REQUIREMENTS

Students must earn a minimum of 20 credits in mathematics for high school graduation.

---

## RECOMMENDED COLLEGE PREP COURSES

*Fulfills "c" requirement for UC and CSU*

Algebra 1 (1 year)  
Algebra 1 (1 year) SDAIE,  
Geometry, Geometry  
SDAIE Algebra 2,  
Algebra 2 SDAIE Pre-  
Calculus  
AP Calculus

---

<b>Principles of Accounting</b>	year long; 5 credits per semester; Grade 11-12
---------------------------------	--

The goal of this course is to develop an understanding of the principles of accounting and the ability to use modern accounting methods. The course includes an introduction to financial statements such as balance sheet and income statement; use of checkbook and bank records; use of special journals and ledgers; analysis of records; payroll records; and adjustments such as those for taxes, depreciation, interest, and uncollectible accounts. Work is done both manually and on the computer using accounting software.

---

<b>Algebra 1 (UC and NCAA approved)</b> <b>Algebra 1 (SDAIE) (UC and NCAA approved)</b>	year long; 5 credits per semester; Grade 9- 12
--	--

**Prerequisites:** EL designation for SDAIE enrollment.

This course is designed to give a basic background in the techniques and topics of classical algebra. In this class, students will receive a foundation in fundamental operations with real numbers and variables. Students will begin to use formal proofs and will study topics including solutions of equations and inequalities, graphing linear functions, working with functional notation, operations with polynomials and verbal problem solving. This Algebra I course will satisfy the Burbank Unified School District's Algebra I graduation requirement.

---

<b>Geometry (UC and NCAA approved)</b> <b>Geometry (SDAIE) (UC and NCAA approved)</b>	year long; 5 credits per semester; Grade 9-12
--	---

**Prerequisites:** EL designation for Transitional enrollment. completion of Algebra 1 with a C or higher.

This course provides an extension of the concept of a formal proof, develops logical thinking, covers the foundations of Euclidean Geometry, and will develop coordinate geometry including the in-depth study of lines.



**Algebra 2 (UC and NCAA approved)** year long; 5 credits per semester; Grade 9-12

**Algebra 2 (SDAIE) (UC and NCAA approved)**

**Prerequisites:** EL designation for SDAIE enrollment. Completion of Algebra 1 and Geometry with C or higher.

This course continues the development of linear and quadratic functions from Algebra 1. New topics included are operations with rational polynomial expressions, three-dimensional linear systems, determinants, quadratic theory, study of the complex number system, and basic trigonometry.

**Pre-Calculus (UC and NCAA approved)** year long; 5 credits per semester; Grade 10-12

**Prerequisites:** Completion of Algebra 2 with a C or higher.

Pre-Calculus is designed to introduce students to the language and concepts necessary for college level math courses. It is designed to prepare students for the study of calculus, to strengthen their use of mathematical application, and to provide opportunities to apply technology to mathematics. Topics stressed include: relations, functions, graphs, trigonometry, vectors, parametric equations, polar coordinates, complex numbers, exponentials, logarithms, sequences, series, iteration, fractals, statistics, probability, data analysis, and limits. A TI graphics calculator is highly recommended.

**AP Calculus AB (UC and NCAA approved)** year long; 5 credits per semester; Grade 11-12

**Prerequisites:** Completion of Pre-Calculus with a C or higher.

This advanced placement course is the equivalent to college level Introductory Calculus. Students study the limits of a function and derivative of polynomial, trigonometric, logarithmic, hyperbolic, and exponential functions. Also included are the techniques of integration and applications to problem solving. The AP Exam in Calculus, given in the spring is mandatory. A TI graphing calculator is required.

**AP Calculus BC (UC and NCAA approved)** year long; 5 credits per semester; Grade 11-12

**Prerequisites:** Completion of AP Calculus AB with a C or higher.

This course builds upon what students learned in AP Calculus AB. Certain integration techniques not explored in AP Calculus AB are covered as is the exploration of Taylor and Maclaurin series, parametric equations, polar curves and vectors. A graphing calculator (preferably a TI) is used in this class.

**AP Statistics (UC and NCAA approved)** year long; 5 credits per semester; Grade 10-12

**Prerequisites:** Completion of Algebra 2 or Pre-Calculus with a C or higher

This course is a college level class designed to introduce students to the major concepts and tools for collecting, analyzing, and drawing conclusions from data. Topics include exploratory data analysis and descriptive statistics, probability for anticipating patterns in the distribution of data, designing experiments, and confirming models through statistical inference. This course prepares students to take the mandatory College Board AP Statistics Exam. Students who complete the course and pass the exam may receive credit for a one-semester college statistics course. This course may be used to meet the UC "c" or "g" requirement.

**Introductory College Mathematics (UC approved and NCAA approved)** year long; 5 credits per semester; Grade 11-12.

**Prerequisites:** Completion of Algebra 2.

The course was created in collaboration with Glendale Community College and is designed to meet the needs of seniors who want to go to a U.C., C.S.U., or Community College. It is further intended for 11th & 12th graders who are not ready for Pre-Calculus after completing Algebra 2. This course is designed to include a study of various functions, trigonometry, probability, statistics, counting methods, and personal financial management. There will be a heavy emphasis on practical applications and collaboration. Major goals of the course include the coverage of California State High School Mathematics Standards from multiple math courses, as well as those from the Entry Level Math Exam, administered by the C.S.U. system.

**Statistics (UC and NCAA approved)** one semester; 5 credits per semester; Grade 11-12.

**Prerequisites:** Completion of Algebra 2. Part of a two-semester sequence which includes Trigonometry.

Statistics is a one semester course designed to introduce students to the study of statistics and probability. Students will be exposed to concepts on how to collect data, analyze data and make inferences from that data. Specifically, they will cover topics such as: types of data, frequency distributions, histograms, statistical graphics, measures of center, measures of variation, basic concepts of probability, random variables, mean, variance, standard deviations, standard normal distribution, estimates, samples, hypothesis testing, correlation, regression, analysis of variance and tests for randomness.

**Trigonometry (UC and NCAA approved)** one semester; 5 credits per semester; Grade 11-12.

**Prerequisites:** Completion of Algebra 2. Part of a two-semester sequence which includes Statistics

Trigonometry is a one semester course designed to enable students to understand trigonometric principles and to be able to apply them in various fields of mathematics. The topics include a study of functions of angles of any size, radian measure, trigonometric equations, identities, vectors, graphing of trigonometric functions, solution of triangles and the use of various trigonometric formulas.

**Business Math** year long, 5 credits per semester; Grade 10, 11, 12

Business Math is a yearlong course focused on financial literacy. Students review basic math skills and explore topics related to business and personal finance, including managing income and expenses, income tax, bank accounts, investments, making financial decisions, and managing business finances.

## PHYSICAL EDUCATION DEPARTMENT

PHYSICAL EDUCATION IS THE STUDY AND PRACTICE OF THE SCIENCE AND ART OF HUMAN MOVEMENT. THROUGH PHYSICAL EDUCATION, THE STUDENT HAS THE OPPORTUNITY TO LEARN TO PERFORM EFFICIENTLY THE MOTOR SKILLS NEEDED IN EVERYDAY LIVING AND IN RECREATIONAL ACTIVITIES. THE STUDENT CAN DEVELOP AND MAINTAIN SOUND PHYSIOLOGICAL FUNCTIONS THROUGH VIGOROUS MUSCULAR ACTIVITY. PHYSICAL EDUCATION PROVIDES SITUATIONS FOR LEARNING TO COMPETE AS WELL AS TO COOPERATE WITH OTHERS IN STRIVING FOR ACHIEVEMENT OF COMMON GOALS. SATISFYING AND SUCCESSFUL EXPERIENCES IN PHYSICAL EDUCATION SHOULD DEVELOP IN THE INDIVIDUAL A DESIRE TO REGULARLY PARTICIPATE IN ACTIVITY THROUGHOUT LIFE. ALL CLASSES TAKEN FOR P.E. CREDIT WILL INCLUDE UNITS IN THE EIGHT STRANDS OF P.E.

Students must be enrolled in a physical education course, or a course that receives Physical education credit in grades nine and ten. All students in grade 9 are required to take the Fitnessgram. If a student in grade nine does not satisfactorily meet five of the six standards of the physical performance test which is the Fitnessgram, the student must take the Fitnessgram again in grade ten. If the student takes the Fitnessgram in grade ten and passes, then the student may be exempted from physical education for two years, grades eleven and twelve. If a student in grade ten does not pass the Fitnessgram, then the student must take a physical education class and the Fitnessgram in grade eleven. If a student in grade eleven does not pass the Fitnessgram, then the student must take a physical education class and Fitnessgram in grade twelve. Passing the Fitnessgram is not a state requirement for a high school diploma. (SB 78, SB 601, Ed Code Section 51241 (b) (1).)

---

### CREDIT REQUIREMENTS:

Students must earn at least 20 credits for graduation.

---

#### **Aerobics (JBHS Only)**

year long; 5 credits per semester; Grade 10-12

**Prerequisites:** None.

Aerobics is a complete physical fitness program that gives students a chance to dance/step to music. As students participate in the basic routine, the body is going through a carefully tested, well monitored fitness workout that strengthens the heart and lungs; includes muscle toning, weight training and endurance work. It may include any activity that conditions the cardio-vascular system.

---

#### **Color Guard/Winter Guard**

ear long; 5 credits P.E per semester; Grade 9-12;

**Prerequisites:** Students are admitted by audition only.

Color Guard students will meet during the Marching Band period first semester and will compete along with the Marching Band. Winter Guard students, comprising a competitive performance group in which basic equipment technique is learned, perform the season show and will compete against other schools at local winter guard association shows.

---

#### **Dance I (UC approved)**

year long; 5 credits of Fine Arts or P.E. credit per semester; Grade 9-12

**Prerequisites:** None

In this course dancers will explore basic dance technique, which will be applied to several different styles of dance, including modern, ballet, social dance, hip hop, jazz, musical theatre, contemporary, and cultural dance. The art of

choreography will also be explored as well as the understanding of correct terminology, body placement, muscle development, dance history, and flexibility. Students will be required to perform in one Dance Concert to fulfill this class. This course is based on the California Dance and P.E. Standards. Proper dance attire will be needed. May be repeated for credit.

---

**Dance II (UC approved)** year long; 5 credits of Fine Arts or P.E. credit per semester; Grade 9-12

---

**Prerequisites:** Dance I

Dance II is a continuation of the Dance I and dancers will explore basic and intermediate dance technique, which will be applied to several different styles of dance, including modern, ballet, social dance, hip hop, jazz, musical theatre, contemporary, and cultural dance. The art of choreography will also be explored as well as the understanding of correct terminology, body placement, muscle development, dance history, and flexibility. Students will be required to perform in one Dance Concert to fulfill this class. This course is based on the California Dance and P.E. Standards. Proper dance attire will be needed. May be repeated for credit.

---

**Dance III (UC approved BHS)** year long; 5 credits of Fine Arts or P.E. credit per semester; Grade 9-12

---

**Prerequisites:** Dance I and II

Dance III is a continuation of the Dance I & II and dancers will explore advanced dance technique, which will be applied to several different styles of dance, including modern, ballet, social dance, hip hop, jazz, musical theatre, contemporary, and cultural dance. The art of choreography will also be explored as well as the understanding of correct terminology, body placement, muscle development, dance history, and flexibility. Students will be required to perform in two Dance Concerts to fulfill this class. This course is based on the California Dance and P.E. Standards. Proper dance attire will be needed. May be repeated for credit.

---

**Dance Production (UC approved)** year long; 5 credits of Fine Arts or P.E. credit per semester; Grade 10-12

---

**Prerequisites:** Teacher approval. Dance I and Dance II recommended.

Dance Production is designed for students who excel in dance and choreography. In this course dancers will continue to explore intermediate and advanced dance technique, which will be applied to several different styles of dance, including modern, ballet, social dance, hip hop, jazz, musical theatre, contemporary, and cultural dance. Students will study dance terminology, body placement, muscle development, and flexibility. Performances, choreography, staging, costuming, and stage craft will be a large portion of this course. Students in Dance Production are expected to create choreographic material that will be performed in two large performances during the school year. The student must maintain a designated grade point average to perform. Proper dance attire will be needed. The California Dance Standards are fulfilled during the course of the year. May be repeated for credit.

---

**PE 9** year long, 10 credits for the year, Grade 9

---

**Prerequisites:** None

This core program includes a solid grounding in the principles of how to develop and maintain physical fitness. Emphasis will be placed on awareness of lifetime fitness and personal fitness goals. Activities will be taught in two or three-week units and include team sports such as volleyball, soccer, softball, hockey, racket sports, track, and basketball, and individual sports such as archery, aerobics, tumbling, weight training, swimming, and golf. 9<sup>th</sup> graders may substitute Pep Squad, Drill Team, Dance, or participation on an athletic team for one or both semesters of this class. There is a required uniform for all P.E. students.

**PE 10-12**

year long, 10 credits for the year, Grade 10-12

**Prerequisites:** None

This course teaches students how to assess their personal fitness levels and set goals for improvement and maintenance. Several activities are integrated throughout the year in order to develop well-rounded individuals. Reviewing rules, skills, techniques, and strategies of recreational and leisure-time activities are included. There is a required uniform for all P.E. students.

**PEOPEL Peer Tutor (JBHS only)**

year long; 5 credits per semester; Grade 9-12

**Prerequisites:** Teacher recommendation.

The Physical Education Opportunity Program for Exceptional Learners (PEOPEL) provides individualized instruction and learning for students who have special needs in Physical Education through peer teaching. Individualized instruction is provided by the Physical Education teacher through student peer-tutors. Peer-tutors are student aides who want to work/play with students who have special needs. They complete an orientation before becoming a PEOPEL peer-tutor. Students and peer-tutors work/play under the direct supervision of the Physical Education teacher. Peer-tutors receive Physical Education credits for this course.

**Weight Training**

year long; 5 credits per semester; Grade 10-12

**Prerequisites:** 10<sup>th</sup> graders must have passed the Physical Fitness Test in 9<sup>th</sup> grade.

Weight training meets the needs of students in the following areas: total body strength, specific large muscle group development, flexibility enhancement, muscular endurance, cardio-vascular fitness, and strength conditioning for specific activities. Students will learn how to use free weights, as well as weight machines. Safety is a priority and students are constantly monitored for correctness in lifting techniques and safety practice. Testing, both written and physical, is conducted at various intervals to monitor student progress

## ATHLETICS

School athletic programs are primarily designed to be a positive educational experience. Competition and teamwork, fair play and sportsmanship, good citizenship and self-discipline are fostered by a sound athletic program under competent adult leadership. The athlete represents dedication, intelligence and discipline. The program is focused on achieving that which is obtainable through perseverance and hard work within the framework of an individual's capabilities, and the building of discipline and self-sacrifice aimed at team success rather than individual honors. Athletics is a means of teaching a fine way of life and understanding and appreciation for good teamwork. Courses in individual sports conditioning are tied to this interscholastic program.

All athletic teams earn 2.5 credits per quarter or a total of 5 credits each semester if the student continues in athletic conditioning or Physical Education. All athletic courses that earn 2.5 or 5 credits of PE will include curriculum units in the eight strands of PE. Sports Manager works with sports teams on stats. As with teachers' assistants, they earn only a "P" or "F". It doesn't count towards Physical Education credits.

---

### CREDIT REQUIREMENTS:

Up to 20 credits may be applied toward meeting the physical education graduation requirement.

---

#### **Pep Squad**

year long; 5 credits per semester; Grade 10-12

**Prerequisites:** Tryouts are required.

This is a performance-based course that teaches the basics of cheerleading and stunt techniques. Students will utilize their creative choreography for performances, both at school and within the community. Members of the Pep Squad must accept leadership roles in many school activities, promoting student participation and school spirit. Within the framework of the course, techniques of leadership, cooperation, creativity, and athletic skills are incorporated into an advanced level course.

---

#### **Baseball Teams**

1 semester (spring); 2.5 credits per quarter; Grade 9-12

**Prerequisites:** Tryouts or recommendation of coach, physical examination, health insurance.

Baseball is offered at the Freshman, Junior Varsity, and Varsity levels. Teams play in approximately 20 contests in this spring season sport.

---

#### **Basketball Teams**

1 semester (winter); 2.5 credits per quarter; Grade 9-12

**Prerequisites:** Tryouts or recommendation of coach, physical examination, health insurance.

Interscholastic basketball teams are fielded at Freshman, Junior Varsity, and Varsity levels for boys, and Freshman, Junior Varsity, and Varsity levels for girls. Approximately 10 league games and 20 games overall are played in each level. Practice begins in September; games begin in December.

---

#### **Cross Country Teams**

1 semester (fall); 2.5 credits per quarter; Grade 9-12

**Prerequisites:** Tryouts or recommendation of coach, physical examination, health insurance.

Cross Country is a sport of distance running. The length of a cross country course is three miles and is run over grass, dirt and concrete. Conditioning workouts usually begin in late June or early July, with competition beginning in early September. The season ends in early November. Practice sessions usually last until 4 or 4:30 p.m.; meets are held on Thursdays.



<b>Football Teams</b>	1 semester (fall); 2.5 credits per quarter; Grade 9-12
-----------------------	--

**Prerequisites:** Tryouts or recommendation of coach, physical examination, health insurance.

Interscholastic football league competition is offered in the fall. Competition is on a ten-game schedule each year for Freshman, Junior Varsity, and Varsity levels. This is a full contact/tackle sport and runs after school (extracurricular), as well.

<b>Golf Teams</b>	1 semester (spring); 2.5 credits per quarter; Grade 9-12
-------------------	--

**Prerequisites:** Tryouts or recommendation of coach, physical examination, health insurance.

Golf is offered at the Varsity and Junior Varsity levels, and is open to both girls in the fall and boys in the spring season.

<b>Soccer Teams</b>	1 semester (winter); 2.5 credits per quarter; Grade 9-12
---------------------	--

**Prerequisites:** Tryouts or recommendation of coach, physical examination, health insurance.

Boys and Girls Soccer is offered at both Varsity and Junior Varsity levels. Teams play approximately 20 league contests in this winter sport.

<b>Softball Teams</b>	1 semester (spring); 2.5 credits per quarter; Grade 9-12
-----------------------	--

**Prerequisites:** Tryouts or recommendation of coach, physical examination, health insurance.

The Girls Softball teams compete in approximately 10 interscholastic league games, plus 10 pre-season games. Junior Varsity and Varsity teams are fielded. Daily practice is held in this spring sport.

<b>Swim Teams</b>	1 semester (spring); 2.5 credits per quarter; Grade 9-12
-------------------	--

**Prerequisites:** Tryouts or recommendation of coach, physical examination, health insurance.

Competition is on Varsity and Junior Varsity levels for both boys and girls in this spring sport.

<b>Tennis Teams</b>	1 semester (fall for boys, spring for girls); 2.5 credits per quarter; Grade 9-12
---------------------	---

**Prerequisites:** Tryouts or recommendation of coach, physical examination, health insurance.

Boys and Girls Tennis is offered at both Varsity and Junior Varsity levels. Teams play interscholastic contests--in the fall for boys and in the spring for girls.

<b>Track and Field Teams</b>	1 semester (spring); 2.5 credits per quarter; Grade 9-12
------------------------------	--

**Prerequisites:** Tryouts or recommendation of coach, physical examination, health insurance.

Running events include: 100M, 200M, 400M, 800M, 1600M, 3200M, 100M and 300M hurdles, 400M relay and 1600M relay. Field events include: high jump, long jump, triple jump, shot put, discus, and pole vault (for boys only). Practice usually ends around 5 p.m. Conditioning workouts begin in January and meets begin in late February. Meets are held on Thursdays, and invitational meets are held on some Saturdays.

**Volleyball Teams**

1 semester (fall/spring); 2.5 credits per quarter; Grade 9-12

**Prerequisites:** Tryouts or recommendation of coach, physical examination, health insurance.

Volleyball is offered at the Varsity, Junior Varsity, and Freshman levels. Teams play approximately 20 contests in this fall sport. In the off season, basic and advanced skills will be taught. This is a competitive class for those who want to improve in this sport.

**Water Polo Teams**

1 semester fall and winter; 5 credits; Grade 9-12

**Prerequisites:** Tryouts or recommendation of coach, physical examination, health insurance.

Teams play approximately 18 games in water polo team competition at both Varsity and Junior Varsity levels. Boys compete in the fall and girls compete in the winter.

**Weight Training – Football (JBHS only)**

1 semester; 5 credits; Grade 9-11

**Prerequisites:** Recommendation of coach, physical examination, health insurance.

This course offers weight lifting and conditioning and football fundamentals for 9<sup>th</sup>, 10<sup>th</sup>, and 11<sup>th</sup> graders. It is offered in the fall, and prepares the athlete for tackle/full contact football

## PRACTICAL ARTS DEPARTMENT AND CAREER TECHNICAL EDUCATION

The Burbank Unified School District believes that today's employees must be well educated with more advanced skills to meet the demands of a highly technical workforce. In addition to technical abilities, today's workers must have a solid foundation in math, science, technical principles, and communication skills.

The Practical Arts and CTE Department offers courses designed to introduce students to "hands on" life-long skills, as well as conceptual and critical thinking skills so necessary in today's rapidly changing world. Opportunities are offered for the development of future employment skills in a number of related fields. Business and industry have provided our programs with jobs at entry-level, while work experience in many fields has allowed students on-the-job training.

Practical Arts and CTE course offerings are not limited solely to preparing for a career; these classes also offer skills and knowledge that will be useful immediately. Practical application offering "how to" knowledge for fixing things, reading a blueprint, or changing a tire is knowledge every person needs.

Practical Arts and CTE encourages both female and male students to enroll in courses which would offer them employment opportunities in non-traditional settings. Although one year of practical arts is required for high school graduation, students are encouraged to enroll in a career technical education pathway to explore possible career areas.

Priority is given to high school juniors, seniors, and students 16 or older for those courses that require off campus internships and/or work experience. Some classes have specific requirements or prerequisites. Most classes count toward the Practical Arts high school graduation requirement, but there are some exceptions. Please refer to the specific course in this guide to verify practical arts credit. CTE courses are free to high school students.

<b>BURBANK USD CAREER TECHNICAL EDUCATION PATHWAYS</b>		
<b>Business Academy- NAF- BHS Only</b>	<b>Construction-JBHS</b>	<b>Information Technology-JBHS Only</b>
Accounting- Fall	Cabinet 1	Digital Applications - 1
Marketing- Spring	Cabinet 2	Digital Applications - 2
Financial Planning- Fall	<b>Aircraft/Small Engines-JBHS</b>	Web Design
Professional Ethics- Spring	Aircraft/ Small Engines 1	Computer Science
Economics-Semester	Aircraft/ Small Engines 2	<b>Stage Craft Technology</b>
	<b>Engineering Academy- NAF</b>	Stage Craft/ Theater Tech 1
	Introduction to Engineering	Stage Craft/ Theater Tech 2
<b>120-Hour Internship Required</b>	Introduction to Computer Programming	Set Design
<b>Retail Marketing</b>		<b>Manufacturing-BHS</b>
Retail Marketing	Physics or AP Physics	Computer Aided Design &

Financial Occupations	Principles of Engineering	Drafting (CAD 1)
	<b>120-Hour Internship Required</b>	Computer Aided Design & Drafting (CAD 2)
<b>Animation-BHS</b>	<b>Digital Media Production</b>	<b>Photography</b>
Animation 1	Digital Media Production 1	Photography 1
Animation 2	Digital Media Production 2	Photography 2
Animation 3	Digital Media Production 3 –	Digital Photography
<b>Medical Academy - NAF</b>	Director’s Cut	<b>Culinary Arts</b>
Global Health- Semester	Professional Film	Culinary Arts 1
Careers in the Medical Field- Semester	Broadcast Journalism	Culinary Arts 2
Anatomy & Physiology		
Sports Medicine		
<b>120-Hour Internship Required</b>		

---

**CREDIT REQUIREMENTS:**

Students must earn at least 10 credits of Practical Arts for high school graduation.

## BUSINESS EDUCATION

---

---

### **Business/Office Occupations** (CTE after school only) 1 semester, 10 credits, Grade 11-12

**Prerequisites:** Must be 16 years of age or older, or have junior standing.

This program provides training for students who are employed. Students are trained to use technology as a tool to perform tasks related to business, and also learn office policy and procedures. Students practice interpersonal communication skills emphasizing effective verbal interactions, careful listening, clearly written correspondence and reading of functional documents.

---

### **Digital Applications (JBHS only)** (also CTE) year long; 5 credits per semester; Grade 9-12

**Prerequisites:** None; for CTE must be 16 years of age or older or have junior standing.

Students will gain exposure and develop an understanding of a variety of digital applications. Utilizing personal computers, scanners, and digital cameras along with software such as Sony Acid, Alice, Audacity, Adobe Photoshop CS3, Movie Maker, Animation, Microsoft PowerPoint, Excel, and Word. Students complete a variety of projects in the fields of business, digital photography, video and audio editing, desktop publishing, and web design. Student projects include but are not limited to photographs, video montages, spreadsheets, brochures, business reports, and web-based student portfolios.

---

### **Principles of IT & Microsoft Office** year long; 5 credits per semester; Grade 9-12

(BHS only)

**Prerequisites:** None

Students will refine basic word processing skills and learn spreadsheet, presentation software, graphics, database management, desktop publishing, basic Internet research techniques and integration of applications. This introductory level course allows students to focus on personal and business applications. Students will create career readiness documents and practice public speaking skills.

## COMPUTER PROGRAMMING

---

**Introduction to Computer Programming** (UC approved JBHS only) year long; 5 credits per semester; Grade 9-12

---

**Prerequisites:** None

There are 3 main goals of Introduction to Computer Programming:

1. To provide students with the basic concepts/principles of most programming languages.
2. To prepare students to take AP Computer Science A.
3. To encourage and provide guidance for students interested in pursuing a degree or career that uses programming.

This course is designed for students with little or no prior knowledge of programming. The intent is that the course could be taught in any programming language and could change from year to year based on the language used on the AP Computer Science A exam, or as industry standard changes. There will be a focus on good programming practices, both in formatting as well as applying algorithms and problem-solving skills.

**Computer Programming** (UC approved BHS only) year long; 5 credits per semester; Grade 9-12

---

**Prerequisites:** Completion of Algebra 1.

This course is designed for students with little or no prior knowledge of programming. The intent is that the course could be taught in any programming language and could change from year to year based on the language used on the AP Computer Science A exam, or as industry standard changes. Topics included here are console input and output, programming calculations and operator precedence, predefined Java Math methods, control statements (if-else, for, while) and object-oriented programming. There will be a focus on good programming practices, both in formatting as well as applying algorithms and problem-solving skills.

There are 3 main goals of Introduction to Computer Programming:

1. To provide students with the basic concepts/principles of most programming languages.
2. To prepare students to take AP Computer Science A.
3. To encourage and provide guidance for students interested in pursuing a degree or career that uses programming.

**AP Computer Science A** (UC approved BHS only) year long; 5 credits per semester; Grade 9-12

---

This course is equivalent to a first-semester, college-level course in computer science. The course introduces students to computer science with fundamental topics that include problem solving, design strategies and methodologies, organization of data (data structures), approaches to processing data (algorithms), analysis of potential solutions, and the ethical and social implications of computing. Topics include review of material taught in the introductory class, in-depth coverage of classes and objects, one and two dimensional arrays, inheritance, polymorphism, and recursion. We also complete 3 complex lab assignments that are provided by the CollegeBoard. The course emphasizes both object-oriented and imperative problem solving and design using Java language. These techniques represent proven approaches for developing solutions that can scale up from small, simple problems to large, complex problems. The AP Computer Science A course curriculum is compatible with many CS1 courses in colleges and universities.

**Honors Computer Science AB** (UC approved BHS only) year long; 5 credits per semester; Grade 10-12

---

**Prerequisites:** Completion of AP Computer Science A.

This college-level course is designed for students who have successfully completed AP Computer Science A and would like to continue their study of programming.

The course will be divided into 2 semesters:

The first semester will cover data structures and will be taught in Java. These structures include linked lists, stacks, queues, sets, maps, hash tables, and binary search trees. The intent of this semester is that it serves as a replacement for AP Computer Science AB, which was cancelled after 2009. There will be a focus on well-designed algorithms, time complexity, efficiency, and recursive methods.

The second semester will be an exploration of the C++ programming language. Since students already have programming experience, this course will move quickly, comparable to a college-level course. It is aligned with the curriculum of CS/IS 135 at Glendale Community College. There will be a focus on how C++ differs from Java in features, capabilities, terminology, and practices

# National Academy Foundation (NAF)

---

## **NAF ACADEMIES**

The National Academy Foundation (NAF) academies focus on growing industries and those that support the workforce needs and interests of local business communities. Students take career-focused courses in conjunction with their general requirements, coupled with work-based learning activities that provide practical learning experiences that complement the academic learning structure.

## **HISTORY AND IMPACT**

For nearly 40 years, NAF has been solving some of the biggest challenges in education and our economy by transforming the American high school experience, igniting students' passion for learning, and giving employers the opportunity to shape America's future workforce.

## **COLLEGE AND CAREER READINESS**

In addition to studying career-focused curriculum and working on collaborative projects, NAF students gain critical career knowledge through a series of work-based learning activities both inside and outside of the classroom. These activities include job shadowing, mock interviews, résumé writing workshops, and culminate with a 120-hour internship. Local business partners work with educators to provide these opportunities that round out students' education. By serving on advisory boards and as mentors, industry partners provide a real-world connection to academy coursework which helps students understand the pathways to career success.

## **NAFTRACK CERTIFICATION**

NAF's student certification assessment system validates successful course completion, projects, and internships. By receiving a passing score on End-of-Course exams and satisfactory scores on project and internship assessments, students earn a NAF credential signifying to post-secondary institutions and employers that they are both college and career ready. With this credential, graduates can benefit from NAFTrack Certified Hiring, a new initiative with some of America's top companies to give special consideration to these graduates for job opportunities and other career support. Graduates of NAF academies complete college faster, earn more, and have stronger ties to their communities than their peers. NAF's 97% senior graduation rate is a testament to this effort.

## **NAF Academy Curriculum**

### **Business Academy (BHS only)**

The Business Academy curriculum covers banking and credit, financial planning, global finance, securities, insurance, accounting, and economics. The Business Academy curriculum and certification is validated by the Council for Economic Education.

### **Engineering Academy (both HS)**

The Engineering Academy curriculum explores principles of engineering, and provides content in the fields of electronics, biotech, aerospace, civil engineering, and architecture. Academies use curriculum from The STEM Academy. They also benefit from support provided by National Action Council for Minorities in Engineering (NACME).

### **Medical Academy (both HS)**

The Medical Academy curriculum includes courses on biotechnology, anatomy, physiology, and global health. The National Consortium for Health Science Education provides an online module for work-based learning.

## **Educational Design**

The NAF educational design is made up of four essential elements of practice: academy development &



structure, curriculum & instruction, advisory board, and work-based learning.

### **Academy Development & Structure**

NAF academies are structured as small, focused learning communities that fit within and enhance high school systems. NAF promotes open enrollment for its academies in order to maximize every student's chance at a successful future. The flexible structure encourages teacher collaboration across subject areas and fosters personalization to meet student, school, district, and state needs and goals.

### **Curriculum & Instruction**

NAF provides a rigorous, industry-validated career-themed curriculum that incorporates current industry standards and practices, literacy strategies, and STEM integration. NAF's instructional practices foster cross-curriculum collaboration so students can make connections across subject areas. The NAF curricula is created in partnership with industry professionals and designed around projects that help students acquire valuable workplace skills and see their education as a step toward long-term career options. NAF empowers teachers to expand the boundaries of the classroom in non-traditional ways that ensure lessons have real-world application to growing industries.

### **Advisory Board**

NAF advisory boards provide an essential bridge between schools and the workplace. Businesspeople and community leaders volunteer on local advisory boards to play an active role in developing their future workforce by shaping talent in high school. Advisory board members collaborate with educators to inform curricula and help organize work-based learning activities. Advisory boards give students the opportunity to build relationships with mentors early and learn from successful adults.

### **Work-Based Learning**

Work-based learning brings the classroom to the workplace and the workplace to the classroom. This instructional strategy provides students with a well-rounded skill set that goes beyond academics and includes the soft skills needed to succeed in college and the working world. NAF's approach to work-based learning is centered on a continuum of work-based learning experiences beginning with career awareness activities, progressing to career exploration activities, and culminating in career preparation activities, including internships. Business people guest speak in classrooms, host college and career skills workshops, and take part in mock interviews. Students have the opportunity to tour work sites, network with, and shadow business professionals. Work-based learning culminates in an internship that allows students to apply their classroom skills and learn more about what it takes to succeed.

---

### **Principles of Accounting (UC Approved)**

1 semester; 5 credits per semester; Grade 10, 11, or 12

(Business Academy - BHS only)

**Prerequisites:** Must be admitted to the BHS Business Academy. Successful completion of "C" or higher in all courses in the Business academy.

Principles of Accounting provides students with an understanding of the accounting process and how it facilitates

decision making by providing data and information to internal and external stakeholders. Students learn that accounting is an integral part of all business activities. They learn how to apply technology to accounting by creating formulas and inputting data into spreadsheets. Students also examine career opportunities and the professional certifications and designations earned by individuals in the accounting profession. **UC approved elective**/high school math credit.

---

**Financial Planning (UC Approved)**

1 semester; 5 credits; Grade 11 or 12

(Business Academy – BHS only)

**Prerequisites:** Must be admitted to the BHS Business Academy with concurrent enrollment in Business Ethics. Successful completion of “C” or higher in all courses in the Academy of Finance.

Financial Planning provides students with an overview of the job of a financial planner, but also addresses the importance of personal financial literacy. Students learn to consider how all aspects of financial planning might affect a potential client, and learn about the importance of financial planning in helping people reach their life goals. This course includes lessons on saving, borrowing, credit, and all types of insurance, and covers various types of investments. Students also examine careers in financial planning. **UC approved elective.**

---

**Marketing (NAF) semester (UC Approved)**

1 semester; 5 credits; Grade 11 or 12

Marketing introduces students to the objectives, strategies, and tools that are important to marketing in any industry. Students become familiar with each phase of marketing and with strategies to build business and brand equity, for both large-scale operations (such as hotel chains) and smaller businesses (such as restaurants). They learn how to assess marketing niches, understand customer and consumer needs, and conduct basic market research. As students study the benefits and potential drawbacks of various marketing channels, they develop an integrated marketing campaign that uses a range of appropriate marketing channels.

---

**Business Economics (UC Approved)**

1 semester; 5 credits; Grade 12

**Prerequisites:** Must be a senior in the BHS Business Academy.

Business Economics introduces students to the key concepts of economics as they pertain to business. This course discusses the American economy and the factors that influence the success of businesses and products. It describes forms of business ownership, discusses the relationship of labor and business, and provides a broad overview of the global economy. Students also examine careers in business, both as employees and as business owners.

---

**Business Ethics (UC Approved)**

1 semester; 5 credits; Grade 11 or 12

**Prerequisites:** Must be admitted to the BHS Business Academy with concurrent enrollment in Principles of Finance. Successful completion of “C” or higher in all courses in the Academy of Finance.

This course introduces the importance of ethics in business. Students focus on the significance of ethics to stakeholders; examine who bears responsibility for monitoring ethics; and explore ethical situations common in organizations. Students examine how ethics affects various business disciplines and consider responsibility, the evolution of ethics in international business, and how the free market and ethics can coexist. **UC approved elective.**

---

**Engineering 1 (UC approved)**

year long; 5 credits per semester; Grade 9-12

This STEM course is a basic introduction to engineering for all students. Exciting hands-on learning activities like data comparison of heart rates, rating consumer products, destructive testing and 3D solid modeling apply math, science, history and English content from other courses in a STEM experience. The course also teaches students the traits and characteristics of successful people along with systems and methods on becoming successful students. The engineering process, groups work, presentations, and CCSS are all a big part of this course. The course's intention and purpose is to educate students in a "main line" method providing STEM education for everyone.

---

**Engineering 2 (UC approved)**

year long; 5 credits per semester; Grade 9-12

---

This STEM course provides opportunities for students and teachers to link content together and apply it to solve problems because more and more jobs demand advanced skills, requiring that team members be able to learn, reason, think creatively, make decisions, and solve problems. An understanding of science, technology, engineering and math and their methods contribute in an essential way to these skills. Engineering 2 is a team based advanced course designed for most students. Students who complete this course will engage in real world case studies and learning activities that focus on the engineering process, making the world a better place to live and work.

---

**Careers in the Medical Field (UC approved)**

1 semester; 5 credits; Grade 11 or 12

---

Health Careers Exploration is a course designed to provide students with the academic and applied skills needed to be successful in health careers. The course focuses on the academic knowledge as well as the applied skills needed daily to be successful in the health careers industry. Focusing on five health careers: diagnostic services, therapeutic services, health informatics, support services, and biotechnology research and development. Students use their academic skills of reading writing, and mathematics to research medical topics and to calculate medical formulations. The health careers industry relies heavily on a student's ability to use their academic knowledge to comprehend the subject matter, to research topics using their language arts skills, write documentation and cite sources. The medical profession is highly academic, this course prepares students for this rigor throughout their occupational career. Mathematics used for many types of calculations for dosages, financial management, and patient diagnosis is used daily in the medical profession. In this course students practice these skills to become highly proficient. Science is an integral component of the medical profession as well, students must be able to take a scientific approach to their work, collecting and analyzing data to make sound decisions for their patients.

---

**Global Health (UC approved)**

1 semester; 5 credits; Grade 11 or 12

---

Global Health enables students to understand public health on a global scale applying their academic base of scientific knowledge. Students learn what disease is and investigate its impacts on world populations applying their scientific foundations. Through the study of health in different societies, they learn about the relationship between health and socioeconomic development. Students learn how environmental, nutritional, and behavioral risk factors jeopardize health. They learn how communities, governments, and cooperative global efforts can intervene to improve health. Students first study each concept as it applies to their own community, and then they look at it in a more global context. Students practice deciphering and interpreting the data they find in tables, charts, graphs, and maps using the scientific process. Students are exposed to working with information compiled by the foremost global health agencies, such as the World Health Organization, the Centers for Disease Control and

Prevention, the World Bank, and UNICEF. Students apply this information through a scientific lens, developing hypothesis, applying data to create conclusions and recommend courses of action. Students have a chance to explore the careers that apply scientific knowledge and research what it would be like to have a career in a global health career field.

**Foundations of Anatomy & Physiology I (NAF) (UC Approved)** 1 semester; 5 credits; Grade 11 or 12

Foundations of Anatomy and Physiology I is the first in a set of two semester-long lab courses that introduce students to basic anatomy and physiology. The first unit covers directional terminology and those aspects of chemistry and cellular biology that students must master in order to study anatomy and physiology. It also teaches students how to use lab equipment safely. Then students learn about the following body systems: integumentary, skeletal, muscular, nervous, and endocrine, with separate lessons on the brain and the senses. Students make connections to their personal health and the prevention of disease for each body system studied. As they conduct research, complete wet labs, participate in a wide range of group activities, and take quizzes and exams, students develop the skills they need for college-level work and careers in the health professions.

**Foundations of Anatomy & Physiology II (NAF) (UC Approved)** 1 semester; 5 credits; Grade 11 or 12

Foundations of Anatomy and Physiology II is the second in a set of two semester-long lab courses that introduce students to basic anatomy and physiology. It builds on the knowledge and skills students developed during the first semester as it teaches students about the following body systems: cardiovascular, respiratory, lymphatic system and immunity, digestive, urinary, and reproductive. This course uses a wide range of assessment products in addition to quizzes and exams to evaluate students' mastery of the material. For their course project, students use models and demonstrations to illustrate an anatomical or physiological function of the human body that they learned about in A&P I and II.

**Sports Medicine (NAF) (UC Approved)** 1 year; 5 credits; Grade 11 or 12

Sports Medicine studies human anatomy and physiology by examining how systems of the body interact through physical activity and inactivity. The prevention, evaluation, treatment, and rehabilitation of illness, disease, and injury are explored. Scientific principles and practical applications are taught through an activity/performance based approach. Modern health and scientific principles of care are prescribed and applied in various scenarios.

## CULINARY ARTS & SCIENCES

---

**Culinary Arts Science I (UC approved JBHS)** year long; 5 credits per semester; Grade 11-12

Prerequisites: None

This laboratory-based course focuses on the physical, chemical and biological characteristics of food. Students will understand the chemical composition of food, chemical bonds and chemical reactions, including molecular gastronomy, nutrition and the biological effects on the human body as well as the science of agriculture or the "from dirt to dish" concept and how it relates to all studies (nutrition, agriculture, Consumer Science). Students will be taught the chemical, physical and biological hazards that affect the quality and safety of food, food production and storage. The course will reinforce product knowledge, vocabulary/terminology, including those from other

disciplines, proper laboratory procedures, scientific method and improve time management skills. There will be focus on meal planning and costs, emphasizing on the science of nutrition and current nutritional concerns, as well as safety and sanitation including ServSafe training. Second semester will focus on international cuisine as well as Family and Consumer Science and Social Science. Students completing this class will obtain a strong foundation in the practical and theoretical knowledge of food sciences as well as the hospitality industry on a whole, leading to a variety of post-secondary opportunities.

---

**Culinary Arts II (UC approved JBHS)**

year long; 5 credits per semester; Grade 11-12

**Prerequisite:** Completion of Culinary Arts Science I

Through this laboratory-based course students will understand the chemical composition of food, chemical bonds and chemical reactions, including molecular gastronomy, nutrition and the biological effects on the human body as well as the science of agriculture or the “from dirt to dish” concept and how it relates to all studies (nutrition, agriculture, Consumer Science). Additionally, students will understand the chemical, physical and biological hazards that affect the quality and safety of food, food production and storage. The course will reinforce product knowledge, vocabulary/terminology, including those from other disciplines, proper laboratory procedures, scientific method and improve time management skills. There will be focus on meal planning and costs, emphasizing on the science of nutrition and current nutritional concerns, as well as safety and sanitation including ServSafe training. Students completing this class will obtain a strong foundation in the practical and theoretical knowledge of food sciences as well as the hospitality industry on a whole, leading to a variety of post-secondary opportunities.

## JOURNALISM & YEARBOOK

---

<b>Broadcast Journalism (UC approved)</b>	year long; 5 credits per semester; Grade 10-12
---	--

**Prerequisites:** Teacher recommendation or Video Production 1.

This course will provide students with the skills and technical abilities to run a studio in a live news broadcast environment. Emphasis will be placed on communication skills, professionalism, responsibility, and teamwork. Students will learn to work equipment appropriately and produce a variety of video projects to air on the program.

<b>Journalism (UC approved)</b>	year long; 5 credits per semester; Grade 9-12
---------------------------------	---

\*\*See Non-Departmental for course description.

<b>Yearbook Design (UC approved)</b>	year long; 5 credits per semester; Grade 9-12
--------------------------------------	---

Yearbook is a year-long class that allows students to learn and develop technical and creative skills in photography, writing, editing and design layout along with business skills in organization, marketing, and deadline-driven planning. The ultimate goal every year is for the staff members to couple these skills and techniques with their artistic and organizational talents and work as a team in order to produce an exceptional record of John Burroughs High School staff and students. Yearbook students will achieve mastery of visual arts and publication design and the terms, processes, and skills that accompany these mediums. Meeting yearbook goals and objectives, caring for special equipment/supplies inherent to the program, meeting specifically assigned tasks by predetermined deadlines will also be fundamental in this course. The ability to work together, ability to celebrate differences among staffers, ability to listen and to speak up, and ability to have fun and enjoy victories both big and small will be needed for a successful year. Each yearbook staff member will be responsible for not only mastering the theory associated with the yearbook but also applying those acquired skills towards the production of the yearbook. Students will apply design and editing principles learned throughout the year and utilize them in order to drive the visual and verbal themes developed in the book. To most closely match a professional publication staff, students will operate within a hierarchy of staff members who report to their peers. It is important for both yearbook staff members and parents to understand this system. Peers will hold students accountable, and in some situations editors may address concerns with individual staffers in the same manner a teacher/employer might conference with students/employees.

## PHOTOGRAPHY/THEATRE/FILM & VIDEO

---

**Photo I** (also CTE) year long; 5 credits per semester; Grade 9-12

See Fine Arts, Visual Arts, for course description.

**Photo II** (also CTE) year long; 5 credits per semester; Grade 10-12

See Fine Arts, Visual Arts, for course description.

## AIRCRAFT/SMALL ENGINES

---

**Aircraft Maintenance and Small Engines I (UC Approved)** year long; 5 credits per semester; Grade 11-12  
(JBHS only and CTE) Prerequisites: None

Students will be introduced to and become familiar with safety, tools, mathematics/measurements and basic terms & definitions as related to shop practices. Component and hardware identification of various systems as related to aircraft and small engines will also be introduced. Students will learn the components and workings of various small engines and systems through hands-on participatory learning. Troubleshooting and proper maintenance of mechanical and electronic equipment will also be emphasized. Students will participate in group activities and develop research skills by the use of CD-ROMs, maintenance manuals and other related publications.

**Aircraft Maintenance and Small Engines II** year long; 5 credits per semester; Grade 9-12  
(JBHS ONLY)

**Prerequisites:** Instructor permission and a letter grade of “C” or better in Aircraft Maintenance and Small Engines I.

The students will **review** shop safety, tools, basic and advanced terms and definitions as related to shop practice. Students will disassemble and reassemble larger more complex engines, such as the Lycoming O-235 four cylinder and Ford V-8 351 Windsor engines. Students will participate on more advanced projects as related to aircraft systems such as sheet metal fabrication, electrical, welding, and component servicing/replacement. Maintenance manual procedures and research will be emphasized due to the higher expectations of an advance class.

## CONSTRUCTION/CABINET TECHNOLOGY

---

**Construction/Cabinet Technology I** year long; 5 credits per semester; Grade 9-12  
(JBHS only) Prerequisites: None

First semester, students will be introduced to a wide variety of hand tools, their uses, and how to care for them. The use of power machines, set up, and safety related to machines will be presented. Students will produce a project after passing safety tests on the power machines. Second semester serves as an introduction to cabinet making. Power machine use and safety will be reviewed, and a safety test will be taken and passed. Students will learn how to draw, design and build a project of their choosing. They will be encouraged to construct

cabinets with operational doors and drawers.

---

**Construction/Cabinet Technology II**

year long; 5 credits per semester; Grade 10-12

(JBHS only)

**Prerequisites:** Completion of Cabinet Technology I.

Students will learn basic turning and carving techniques. After learning tool use, care, and sharpening, students will produce basic cuts on the lathe and carving tools. Project of each student's choice will be designated and produced.



## OTHER VOCATIONAL/CAREER TECHNICAL EDUCATION COURSES

---

--- Please note that not all classes are offered every year. ---

**Animal Care Occupations** (CTE) year long; 10 credits per semester; Grades 10-12

**Prerequisites:** Must be 16 years of age or older, or have junior standing

This course is designed to train students for jobs working with animals in locations such as animal shelters, or veterinary clinics or animal hospitals. Students acquire skill and knowledge related to animal handling, animal identifications, common diseases and illnesses as well as specific terminology and vocabulary. Proper handling and animal safety precautions are stressed in all phases of the course.

**Animation (BHS only)** (CTE) year long; 5 credits per semester; Grade 11-12

**Prerequisites:** Must be 16 years of age or older, or have junior standing.

This course provides students with the skills necessary for entry-level work in cartooning and two and three dimensional character development, and the process of creating animated products, including computer-designed characters. Advanced students are offered instruction in two and three-dimensional techniques. Students may enter contests and submit films for exhibition. They may also create a “reel” to submit to various commercial animation industries.

**Advanced Animation** (CTE) year long; 5 credits per semester; Grade 10-12

**Prerequisites:** Animation I

Advanced Animation takes the fundamentals and allows the students to go further in developing their skills. Individual and small group projects will allow the student to specialize in an area of animation such as: Character Design; Storyboarding; Coloring; and Editing. Some students will choose to work in a team or with a partner, as in the “real world”. Digital editing, sound, and some computer animation (such as Flash) will be covered. The class may be taken up to three times and has a prerequisite of Animation Fundamentals. Higher level drawing skills and imagination are a necessary part of the class.

**Financial Occupations** 1 semester; 5 credits; Grade 10-12

Financial Occupations trains students for entry-level positions in the financial sector or is an introduction to the world of finance before advanced schooling. Major areas of training include an introduction to financial institutions and the basics of economic concepts. Emphasis will be placed on having become aware of the major sectors of the world of finance: banking, stocks, bonds, investments, financial markets, and real estate.

**Retail Sales/Work Experience** (CTE after school only)

1 semester; 10 credits; Grade 11-12

**Prerequisites:** Must be 16 years of age or older, or have junior standing.

This program is designed to provide students with competencies necessary for entry-level employment in merchandising and retail sales occupations. Students will acquire knowledge of basic sales techniques, cash register training, employer-employee and customer relations, sales promotions, stock keeping, and inventory control. Classroom and community placement (5 credits); COOP Vocational Education (10 credits).

**Sports Medicine** (CTE) UC Approved

year long; 5 credits per semester; Grade 11-

12

**Prerequisites:** Must be 16 years of age or older, or have junior standing. Biology, Algebra

Sports Medicine studies human anatomy and physiology by examining how systems of the body interact through physical activity and inactivity. The prevention, evaluation, treatment, and rehabilitation of illness, disease, and injury are explored. Scientific principles and practical applications are taught through an activity/performance based approach. Modern health and scientific principles of care are prescribed and applied in various scenarios

**Stagecraft Technology**(CTE) (UC approved) year long; 10 credits of Fine Arts/Practical Arts Credit per semester.

This course trains students to conceptualize and design artistic interpretations and create functional scenery, properties, lighting and sound for events and informal or formal theatrical productions. Students also learn the basic physical properties in the technical aspects of theatre such as light, color, and sound. Students gain hands-on experience by demonstrating their skills at local school and/or community events. Students may earn credits with unpaid, community classroom, activities.

## SCIENCE DEPARTMENT

The science program provides all students with the opportunity to study the methods of science (science as a human process of studying the world), the content of science including physical science and life science, science in personal and social perspectives, history of science, and unifying concepts and processes. It is the District's goal that all students will achieve scientific literacy by:

- becoming familiar with the natural world and respecting its unity;
- becoming aware of the connectedness of human beings, nature, and technology;
- understanding some of the key concepts and principles of science;
- knowing that science is a human endeavor;
- being able to use scientific knowledge and ways of thinking for personal and social purposes.

---

### GRADUATION REQUIREMENTS:

Students must earn a minimum of 20 credits for graduation, which include: 1 year physical science (10 credits)  
1 year life science (10 credits)

---

### RECOMMENDED COLLEGE PREP COURSES

*Fulfills "d" requirement for UC and CSU*  
Biology, SDAIE Biology, AP Biology  
Chemistry, SDAIE Chemistry, AP Chemistry  
Physics, AP Physics  
Anatomy and Physiology  
Geo-Science, SDAIE Geo-  
Science Honors Chemistry  
Marine  
Biology  
Honors  
Biology

Students who are interested in taking Honors or Advanced Placement (AP) courses should be those students with proven academic achievement as evidenced by superior prior grades, and outstanding performance on District Common Assessments. It is also recommended that students interested in Honors or Advanced Placement courses score at the proficient or advanced level on the California Standards Tests (CSTs). In addition, students may be asked for an on-demand writing sample. Potential Honors/AP students should be organized, responsible and able to manage a difficult course load. They should also be academically focused and interested in studying topics more rigorously and in more depth. If a student wants additional information about Honors/AP courses, he or she should consult with the high school guidance counselor.

---

**Anatomy and Physiology (UC and NCAA approved)**    year long; 5 credits per semester; Grade 11-12

**Prerequisites:** Completion of Biology and Chemistry.

The course is a detailed study of the anatomical structures and physiological processes of human organ systems. Laboratory work investigating physiological processes, as well as dissection of anatomical structures, will be emphasized.

**Advanced Astronomy** (UC approved BHS Only) year long; 5 credits per semester; Grade 10-12

**Prerequisite:** Geometry, Physics, recommended

Advanced Astronomy is a science for motivated high school juniors and seniors who want another laboratory based science course. This course will explore our place in the universe. We examine our planet; other planets, the Sun, and the Solar System as a whole galaxy; stars and stellar evolution; and the large-scale structure of the Universe. We will also focus on the development of modern astronomy and its technics, the use of astronomical instruments and recent discoveries in astronomy and cosmology.

**Biology** (UC and NCAA approved) year long; 5 credits per semester; Grade 10-12  
**Biology (SDAIE)** (UC and NCAA approved)

**Prerequisites:** None. EL designation for SDAIE enrollment.

This class introduces students to a comprehensive curriculum which includes introductory units in biochemistry, microbiology, botany, human biology, genetics, ecology, and the environment. Laboratory investigations are an integral part of the course, and require some mathematical skills in the examination of concepts and lab experiments. Recent advancements in biology, as well as fundamental concepts including physiological and phylogenetic relationships, are studied.

SDAIE Biology uses SDAIE instructional techniques, but contains the same core content as Biology.

**Honors Biology** (UC and NCAA approved) year long; 5 credits per semester; Grade 9 or 10

This course is the same as Biology with additional lab experiments, oral reports and course work on DNA, genetics, virus and bacteria identification, enzyme testing, carbohydrates and identification of fat protein, pacing of the heart and studies of algae/fungi.

**AP Biology** (UC and NCAA approved) year long; 5 credits per semester; Grade 11-12

**Prerequisites:** Completion of Biology, Chemistry and Algebra.

AP Biology places emphasis upon the principal topics covered and objectives of an introductory college level biology course. Lectures, class discussion, laboratory projects, and home study will give each student a fundamental understanding of advanced biology.

**Chemistry** (UC and NCAA approved) year long; 5 credits per semester; Grade 10-12

**Chemistry (SDAIE)** (UC and NCAA approved)

**Prerequisites:** Completion of Algebra 1; concurrent enrollment in Geometry or completion of Geometry. EL designation for SDAIE enrollment.

Chemistry is designed to give students a basic understanding of theory, composition and behavior of matter. Emphasis is placed on measurement, the mole concept, atomic structure, and factors influencing chemical reactions. Students will be introduced to and become familiar with laboratory equipment and techniques, and will be expected to emphasize their ability to use critical thinking and problem solving skills. Experiments, demonstrations, and discussions will be employed.

The core curriculum is maintained in the SDAIE classes, with activities adjusted to meet the level of language acquisition.

**Honors Chemistry** (UC and NCAA approved) year long; 5 credits per semester; Grade 10- 12

**Prerequisites:** Completion of Algebra; concurrent enrollment in Geometry or higher math recommended.

Honors Chemistry is an accelerated college prep course which will cover extensive chemical theories from Stoichiometry to Electrochemistry. Emphasis will be on critical thinking, problem solving, experiments, demonstration, discussion.

**AP Chemistry** (UC and NCAA approved) year long; 5 credits per semester; Grade 11-12

**Prerequisites:** Completion of Algebra, concurrent enrollment in Geometry or higher math, and completion of Chemistry or Honors Chemistry.

AP Chemistry is a lecture/laboratory-based course that emphasizes the principal topics covered in an introductory college level chemistry course. It will include chemical theory and applications and will develop students' skill in critical thinking, problem solving, discussions, and experimentation. Lab time in addition to regular class time is required.

**Earth and Space Science** (UC and NCAA approved) year long; 5 credits per semester; Grade 9-12

**Earth and Space Science (SDAIE)** (UC and NCAA approved)

**Prerequisites:** None. EL designation for SDAIE enrollment.

Earth and Space Science is a 10 credit research based lab science course emphasizing an understanding of Earth's place in the universe and dynamic Earth processes. This includes the study and investigation of the energy in Earth's systems and biogeochemical cycles; structure and composition of the atmosphere, ocean currents, weather systems, and meteorology; natural resources, natural hazards, geology, and plate tectonics; and the formation of the universe, elemental composition and life cycle of stars, and astronomy. Students will evaluate the impact of these natural processes on humans and humans impact on Earth and in space. Students will develop and complete scientific experiments, models, and projects that address California state standards, CCSS, and NGSS. Throughout the class, students will apply scientific inquiry principles to real-life and virtual situations by developing hypotheses, collecting data, modeling data, analyzing results, writing lab reports, writing and solving equations.

**Micro/Marine Biology** (UC and NCAA approved) year long; 5 credits per semester; Grade 11- 12

**Prerequisites:** Completion of Biology or Chemistry, or teacher recommendation.

This course acquaints students with the major microbiological and marine organisms, including bacteria, algae, invertebrates, fish, and marine mammals. Students will learn the major structure and function of the organisms and how they affect our world. Classroom activities will promote technical lab competence and utilize the scientific process of research and reporting.

**Physics** (UC and NCAA approved) year long; 5 credits per semester; Grade 11-12

**Prerequisites:** Completion of Algebra 1 and Geometry; concurrent enrollment of Algebra 2.

This course is a qualitative and quantitative study of the central concepts of physics including mechanics, thermodynamics, waves, sound, light, electricity and magnetism, and modern physics. Emphasis will be placed on mental imagery that relates to things and events that are familiar in the everyday environment. Physics

concepts

will be studied with the use of demonstrations, laboratory investigations, multimedia presentations, and student projects. Laboratory work will include some computation.

---

**AP Physics I (UC and NCAA approved)**

Year-long; 5 credits per semester; Grades 10-12

**Prerequisites:** Grade of 'B' or better in Geometry, OR, a 'B' or better in Regular Physics. PLUS, concurrent enrollment in Algebra II or higher math.

This is a college-level course that provides a systematic introduction to the main principles of physics – in particular, mechanics and electric circuits. This course will provide foundational physics concepts for students interested in deeper study of life sciences, pre-medicine, and some courses for physicists and engineers. It will also offer an excellent preparation for rigorous university physics courses for physicists and engineers.

---

**AP Physics II (UC and NCAA approved)**

Year-long; 5 credits per semester; Grades 11-12

**Suggested Prerequisites:** Grade of 'C' or better in AP Physics 1, OR, a 'B' or better in Regular Physics with instructor consent. PLUS, concurrent enrollment in Pre-Calculus or higher math.

This is a college-level course that provides a systematic introduction to the main principles of physics. It covers electricity and magnetism, atomic and nuclear physics, optics, heat, and fluid mechanics. This course is designed as a follow-up course to AP Physics 1, and will provide foundational physics concepts for students interested in deeper study of life sciences, pre-medicine, and some courses for physicists and engineers. It will also offer an excellent preparation for rigorous university physics courses for physicists and engineers.

---

**AP Physics C (UC and NCAA approved)**

Year-long; 5 credits per semester; Grade 12

**Prerequisites:** Grade of 'B' or better in AP Physics 1 and in AP Physics 2, PLUS instructor consent.

This is a college-level course that provides a systematic introduction to the main principles of physics. It covers mechanics, and electricity and magnetism. Problem solving is emphasized. It is assumed that the student is familiar with calculus, including derivatives and integrals. This course will offer preparation for more rigorous university courses in science and engineering.

## SOCIAL SCIENCE DEPARTMENT

The recent changes in world politics and national alignments, domestic issues concerning the environment and morality, the influx of new immigrants, the war on drugs--all should help make these courses meaningful and interesting. Every teacher will provide students with the background necessary to understand these issues and the information needed to make some personal decisions. The staff is committed to a broad-based curriculum using speakers, videos, group work, primary source materials, simulations, and discussions. Through the study of the curriculum, students will become excited about history and other social science issues.

---

### CREDIT REQUIREMENTS:

Students must earn 40 credits for graduation and pass all of the following courses:

World History

U.S. History

Economics (1 semester course)

Government (1 semester course) or Mock Trial/Government (1 semester course)

---

### RECOMMENDED COLLEGE PREP COURSES:

*Fulfills "a" requirement for UC and CSU*

AP European History, U.S. History, Transitional U.S. History, AP U.S. History World

History, SDAIE World History, AP World History

Government, SDAIE Government, AP Government

Mock Trial

*Fulfills "g" requirement*

Psychology, Sociology

Economics, SDAIE Economics, Honors Economics, AP Economics

Students who are interested in taking Honors or Advanced Placement (AP) courses should be those students with proven academic achievement as evidenced by prior grades, and outstanding performance on District Common Assessments. It is also recommended that students interested in Honors or Advanced Placement courses score at the proficient or advanced level on the California Standards Tests. Potential Honors/AP students should be organized, responsible and able to manage a difficult course load. They should also be academically focused and interested in studying topics more rigorously and in more depth. If a student wants additional information about Honors/AP courses, he or she should consult with the high school guidance counselor.

---

### **Economics (UC and NCAA approved)**

1 semester; 5 credits; Grade 12

**Prerequisites:** None

This 12<sup>th</sup> grade economics course teaches students skills and attitudes useful in making wise economic decisions in their own lives and includes instruction about the basic institutions in both private and public sectors which operate or affect the economy. Students will gain insight into how their individual situations are affected by these institutions so that they might behave in an economically knowledgeable manner. Students will also be introduced to more advanced economic study and understanding.

---

### **Economics (SDAIE) (UC and NCAA approved)**

1 semester; 5 credits; Grade 12

**Prerequisites:** EL designation.

The content of this course corresponds to Economics, but employs SDAIE instructional techniques to help EL students to successfully access the curriculum.

---

<b>AP Economics (UC and NCAA approved)</b>	1 semester; 5 credits; Grade 12
--	---------------------------------

---

**Prerequisites:** Completion of US History

AP Macroeconomics is a semester long course designed to replicate the introductory macroeconomics course taught in a university setting. Over the next several months, we will explore economic concepts and their application to problems of public policy. We will look at issues such as inflation, unemployment, and their possible cause and cures. Additionally, we will analyze the role of the government and the Federal Reserve in the economy.

---

<b>Government (UC and NCAA approved)</b>	1 semester; 5 credits; Grade 12
--	---------------------------------

---

**Prerequisites:** None

This one semester course of study explores the basic origins, philosophy, functions, and organization of our federal, state, and local governments. Students learn to analyze historical and contemporary political data, separate fact and opinion, identify values and biases, and understand multiple political perspectives. The class is designed to help students intelligently participate in our system of government, as well as to better understand their rights and responsibilities as citizens in a democracy.

---

<b>AP Government (UC and NCAA approved)</b>	1 semester; 5 credits; Grade 12
---	---------------------------------

---

**Prerequisites:** Completion of US History and English 11.

This course follows the Advanced Placement guidelines for U.S. Government study. This course will examine the following major content areas: Constitutional underpinnings of democracy, political beliefs and behaviors of individuals; political parties and interest groups; mechanisms that facilitate the communication of interests and preferences by like-minded citizens; the Congress, the Presidency, the bureaucracy and the Federal Courts; institutions and policy processes; and civil liberties and civil rights.

---

<b>Government (SDAIE) (UC and NCAA approved)</b>	1 semester; 5 credits; Grade 12
--	---------------------------------

---

**Prerequisites:** EL designation.

The SDAIE Government curriculum emphasizes federal government and draws on examples from American history and other global societies to compare different systems of government in the world today. Supplementary textbooks assist students so that their study is thoughtful and deliberate; examinations and assignments are designed to encourage students whose primary language is other than English. The course of study is the culmination of the civil literacy strand that prepares students to vote and to participate in government.

---

<b>Psychology (UC and NCAA approved)</b>	1 semester; 5 credits; Grade 11-12
--	------------------------------------

---

**Prerequisites:** None

Psychology offers a basic introduction to the study of human behavior. It includes a variety of subject matter and activities that will enable students to gain practical information regarding their own psychological development. In this age of “pop” psychology, there is a smorgasbord of “self-help” books, cults, groups, programs, etc., waiting to offer the unwary consumer a host of easy answers to complex emotional and social conflicts. This course will provide students with information from available scientific knowledge in psychology against which they may measure their own beliefs and assumptions regarding the nature of human behavior.



**AP Psychology (UC and NCAA approved)**

year long; 5 credits per semester; Grades 11-12

**Prerequisites:** Completion of AP/Honors Application;

The AP Psychology course is designed to introduce students to the systematic and scientific study of the behavior and mental processes of human beings and other animals. Students are exposed to the psychological facts, principles, and phenomena associated with each of the major subfields within psychology. They also learn about ethics and methods psychologists use in their science and practice. The AP Psychology course is designed to prepare students for the Advanced Placement Psychology exam. The AP Psychology exam, designed by the AP Test Development Committee, allows students to demonstrate mastery of skills equivalent to those typically found in introductory psychology classes. Students who do not take the AP exam will not receive the weighted grade point for either semester the class is taken.

**Sociology (UC and NCAA approved)**

1 semester; 5 credits; Grades 11-12

**Prerequisites:** None

The concepts of sociology will be explored, including the methods of social research and the formulation and articulation of opinions about current social issues. The course will cover socialization from birth until death and emphasize the concepts of social change. Students will be required to do both academic and field research and to actively participate in class discussions.

**AP European History (UC and NCAA approved)**

year long; 5 credits per semester; Grade 10

**Prerequisites:** None

The study of European history since 1450 introduces students to cultural, economic, political, and social developments that played a fundamental role in shaping the world in which they live. Without this knowledge, we would lack the context for understanding the development of contemporary institutions, the role of continuity and change in present-day society and politics, and the evolution of current forms of artistic expression and intellectual discourse. In addition to providing a basic narrative of events and movements, the goals of the AP program in European History are to develop (a) an understanding of some of the principal themes in modern European History, (b) an ability to analyze historical evidence and historical interpretation and (c) an ability to express historical understanding in writing. The AP European History examination given in the spring is mandatory. Students who do not take the AP exam will not receive the weighted grade point for either semester the class is taken.

**Ancient Greek and Roman History and Archaeology** year long; 5 credits per semester; Grade 11-12**BHS Only (UC approved) Prerequisite:** None

This course introduces students to the history of western culture and thought through a series of area-studies, including the ancient Greek and Roman Empires, which focuses on ancient literature, language, history, and archeological studies. Knowledge of cultural components, cultural values, literature, and major issues facing these empires are emphasized. Knowledge and application of the research process are emphasized through a variety of activities. These include writing assignments, research papers, technology, art history, and oral presentations. The course curriculum and assessments are designed to prepare students for higher level social science courses and testing.

**U.S. History (UC and NCAA approved)**

year long; 5 credits per semester; Grade 11

**U.S. History (SDAIE) (UC and NCAA approved)****Prerequisites:** None. EL designation for SDAIE enrollment.

This course examines the major turning points in 20<sup>th</sup> century America. It reviews the nation's beginnings, its democratic ideals, and the crises of the 19<sup>th</sup> century, then looks at how industrialization, new technology, and

war have impacted 20<sup>th</sup> century society and culture. The course examines the major social issues of the 20<sup>th</sup> century and traces their causes in historical events. The course examines America's role as a world power and its continuing impact on world events.

---

**AP U.S. History (UC and NCAA approved)**

year long; 5 credits per semester; Grade 11

**Prerequisites:** None.

This course follows the Advanced Placement guidelines for U.S. History and is intended to be the equivalent of a freshman college course. It covers American history from the colonial era to the present. It stresses analytical thought, research and study skills. Students learn social science concepts in history, political science, geography and economics, as well as major interpretive trends and a broad body of historical knowledge. Emphasis will be placed upon critical analysis in both thought and writing. Students will interpret and apply data from original documents and use historical data to support an argument or position. The AP U.S. History Exam given in the spring is mandatory. Students who do not take the AP exam will not receive the weighted grade point for either the fall or spring semester.

---

**World History (UC and NCAA approved)**

year long; 5 credits per semester; Grade 10

**World History (SDAIE) (UC and NCAA approved)**

**Prerequisites:** None. EL designation for SDAIE enrollment.

This course covers topics chronologically, beginning with ancient through medieval times, and moves through the Renaissance, French Revolution, Industrial Revolution, the development of democracy, imperialism, 20<sup>th</sup> Century crises, and technological advances. Selected civilizations will be studied from the Western and non-Western worlds, with emphasis on the study of European culture and its significance to the intellectual, political, and social development of the United States. Cultures will be compared in terms of ethical systems, philosophies, laws, languages, literature, arts, and religions, and will emphasize historical events that have had an impact on the development of particular cultures. Basic social science skills and concepts will be emphasized. The core curriculum is maintained in SDAIE classes with activities adjusted to meet the level of language acquisition

## SPECIAL EDUCATION DEPARTMENT

The Department of Special Education provides support for students with disabilities. Based on assessment of a student's needs, Individual Education Plans (IEP) are written to provide a free appropriate public education in the least restrictive environment.

Service options to meet student needs include the Resource Specialist Program (RSP), Special Day Class (SDC), Severely Handicapped (SH) programs, Deaf and Hard of Hearing (DHH) programs and Community Based Instruction (CBI) offers students instruction in basic living skills. Designated Instructional Services (DIS) such as speech and language, occupational therapy and adapted physical education are provided as needed.

Students in our Resource Specialist Program (RSP) receive the majority of their academic instruction in mainstream classes. Students in Special Day Class (SDC) receive the majority of their instruction in special education classes. The department offers courses in English, Math, Biology, Health, Geo Science, World History, American History, Economics, and Government, all of which are taught by special education teachers for students who need greater levels of assistance than are available in general education settings. Burbank High School serves students in the Deaf and Hard of Hearing (DHH) program, where a similar range of options is available to meet each student's needs. Study Skills classes are available for students who need added support to succeed in their mainstream classes. Finally, special education teachers work in collaboration with the general education staff to implement accommodations and modifications to the California Content Standards when needed.

A student with special needs is assigned a case manager who works with the student, the parent/guardian, and the counseling department to ensure that courses are selected and services are provided in accordance with the student's IEP. Case managers monitor student progress and report to the students and parents/guardians through quarterly progress reports and annual IEPs.

Students with special needs who are coming from placements outside of the Burbank Unified School District must pre-register at the Office of Special Education at District headquarters before registering at the high school.

## NON-DEPARTMENTAL COURSES

Some classes do not fit into any one department's structure, but, instead, transcend department boundaries. Students who take these classes receive elective credit toward graduation. As service learning/community service takes on increasing importance, these courses become even more relevant to the entire instructional program.

---

### CREDIT REQUIREMENT:

70 credits of elective courses are required for graduation. All of the courses listed under non-departmental may be applied toward elective credit.

---

### RECOMMENDED COLLEGE PREP COURSES

*Fulfills "g" requirement for UC and CSU*  
Journalism

---

<b>Health/Careers</b>	year long; 5 credits per semester, Grade 9
<b>Health/Careers (SDAIE)</b>	

**Prerequisites:** None. EL designation for SDAIE enrollment.

Health class is intended to provide students with the skills and knowledge necessary to maintain physical, mental/emotional, and social well-being. Students will focus on obtaining accurate information, developing lifelong positive attitudes and behaviors, and making wise decisions related to their personal health. Students will study health issues by examining their life styles, selecting goals for good health and learning how to achieve and maintain optimum health. They will be involved in decision making about wise health practices, learning that all choices carry with them consequences, either good or bad. Behaviors that may prevent illness, accidents, and stress, and that promote wellness, will be studied. In accordance with the California Healthy Youth Act ~ Education Code 51930 -51939, HIV/AIDS and Comprehensive Sexual Health Education will be covered in this course. The California Health Education Content Standards for Health that will be covered in this course can be found at: <http://www.cde.ca.gov/be/st/ss/documents/healthstandmar08.pdf>

Students will have the opportunity to investigate potential career choices, along with creating a resume, filling out a job application and preparing for a job interview through the Get Focused, Stay Focused curriculum.

---

<b>Journalism</b>	year long; 5 credits per semester; Grade 9-12
-------------------	---

**Prerequisites:** None

Journalism is designed for students to be informed about the world around them and to confront important local, state, national, and international issues. Students will analyze electronic and print media and then learn to write journalistically, while acquiring the skills necessary to produce a newspaper. Ethics and accuracy are stressed.

---

<b>Journalism, Advanced</b>	year long; 5 credits per semester; Grade 9-12
-----------------------------	---

**Prerequisites:** Successful completion of Journalism

This course reinforces those skills taught in Journalism. Student will also produce the school newspaper from inception to distribution.

---

<b>Student Leadership (ASB)</b>	year long; 5 credits per semester; Grade 9-12
---------------------------------	---

---

**Prerequisites:** Open to elected or appointed ASB officers and commissioners, or by teacher recommendation.

The leadership class should be taken by all student body officers, class officers, and rally commissioners. The class will explore leadership techniques, responsibility of leaders, and group dynamics. Much time will be spent organizing activities for the school and setting goals for the student body. The course offers instruction in leadership theory, speech, and analysis of small and large group behavior.

---

<b>Teacher/Office/Library Aide (TA)</b>	1 semester; 5 credits; Grade 11-12
---	------------------------------------

---

**Prerequisites:** By teacher or office recommendation.

Aides are expected to be responsible and have good attendance habits. Valuable vocational training may be gained by students who show interest and a willingness to work. Many of the departments can accept an aide only certain periods of the day; others need help regularly. No more than one TA class may be taken during any one semester. Grade issued is pass/fail only.

---

<b>College Peer Mentors</b>	Year long; 5 credits per semester; Grade 11-12
-----------------------------	--

---

**Prerequisites:** Students are admitted by application and interview only; recommended 2.5 GPA or higher and on-track for 4-year college admissions.

The College Peer Mentors course is aimed at providing an understanding and mastery of the college admissions process. Students will be resources for their peers with knowledge of college search tools, standardized testing (SAT, ACT, PSAT), college applications (community college, CSU, UC, Private, Out of State), the basics of financial aid (FAFSA, Cal Grants, CSS Profile), career exploration, and tracking students' post-high school plans. Students will work with counselors to learn interpersonal and communication skills and will develop their leadership, cultural awareness, personal maturity, and decision-making skills throughout the course of the year. College Peer Mentors will be trained by counselors, with the expectation that they will meet with their peers to assist them with the college process.

---

<b>Student Tutor</b>	1 semester; 5 credits; Grade 11-12
----------------------	------------------------------------

---

**Prerequisites:** 3.0 overall GPA. Must have taken class in which tutoring assignment is desired and earned an "A" in the class. Also, teacher recommendation is required.

Being a student tutor offers the opportunity to work directly with less advanced students in specific subject areas.

---

<b>Yearbook Design (UC approved)</b>	year long; 5 credits per semester; Grade 9-12
--------------------------------------	---

---

**Prerequisites:** Advisor's approval.

Yearbook is a year-long class that allows students to learn and develop technical and creative skills in photography, writing, editing and design layout along with business skills in organization, marketing, and deadline-driven planning. The ultimate goal every year is for the staff members to couple these skills and techniques with their artistic and organizational talents and work as a team in order to produce an exceptional record of John Burroughs High School staff and students. Yearbook students will achieve mastery of visual arts and publication design and the terms, processes, and skills that accompany these mediums. Meeting yearbook goals and objectives, caring for special equipment/supplies inherent to the program, meeting specifically assigned tasks by predetermined deadlines will also be fundamental in this course. The ability to work together, ability to celebrate differences among staffers, ability to listen and to speak up, and ability to have fun and enjoy victories both big and small will be needed for a successful year. Each yearbook staff member will be responsible for not only mastering the theory

associated with the yearbook but also applying those acquired skills towards the production of the yearbook. Students will apply design and editing principles learned throughout the year and utilize them in order to drive the visual and verbal themes developed in the book. To most closely match a professional publication staff, students will operate within a hierarchy of staff members who report to their peers. It is important for both yearbook staff members and parents to understand this system. Peers will hold students accountable, and in some situations editors may address concerns with individual staffers in the same manner a teacher/employer might conference with students/employees.